

GENERAL INFORMATION

1.1 SCOPE OF MANUAL

This manual contains operating and maintenance information on the economy model Signal Converter (EC-SCT), manufactured by MOORE INDUSTRIES INC., Sepulveda, California. The manual consists of six sections, as follows:

Section 1, General Information, introduces the equipment function and describes the equipment physical appearance, the equipment specifications, and options available for the unit. The introduction also provides information on the use and description of the MOORE model numbering system.

Section 2, Calibration, provides all the information necessary to calibrate the unit before installation. This section contains a list of the tools necessary for calibrating the equipment; and illustrates the test setups essential to perform that task. The section also lists the various procedures required for calibration of the units in any configuration.

Section 3, Installation and Operation, supplies all the information needed to install and operate the equipment. The section contains figures that specify the installation requirements for the units, and text that informs the user on recommended wiring practices for the equipment as well as defines the electrical connections for each unit regardless of physical modifications. A brief outline of periodic observations required during the equipment operation is also included here.

Section 4, Theory of Operation, gives the maintenance personnel a detailed explanation of the internal function of the unit. The circuit theory is based on a block diagram that shows the functional elements of the unit. Each element operation is then described, first in relation to the other elements, then independently where its major components' use and purpose are described.

Section 5, Maintenance, offers complete disassembly procedures for all unit configurations available. Troubleshooting information is also provided in this section as well as component replacement techniques to aid the technician in the repair of the equipment.

Section 6, Unit Documentation, acquaints the user with the MOORE IND. computerized parts listing and identification system. The section also provides a recommended spare parts list. All schematics and parts assembly drawings referred to by the text are located in the back of Section 6.

1.2 EQUIPMENT DESCRIPTION

The EC-SCT converts either input voltages to current outputs of different ranges or input current ranges to different voltage ranges. Inputs in the

millivolt range (10 to 400 millivolts) may also be applied for conversion to a higher range of voltage output or to current output.

1.3 PHYSICAL DESCRIPTION

The unit is available in several different physical configurations. In general, the unit consists of a single circuit board that holds all the electronic components.

The board is enclosed in a protective housing, and the entire assembly may be installed in a number of ways. Specific details about each unit and the options available are outlined in this section. Electrical connection information is given in Section 3, Installation and Operation.



EC Enclosure

1.3.1 NEMA Boxes Options Description

Units may be enclosed in NEMA boxes to ensure protection against harsh environments that may be damaging to the unit. Four configurations are available for this purpose.

Oil Tight (OT) NEMA Box Option. This enclosure consists of a NEMA 12 box construction, with two cover-holding screw clamps, mounted opposite to

the hinged side of the cover (right side). These enclosures are oil and dust tight only. Conduit holes, fittings, or knockouts are not provided on these boxes. Suggested fittings are "Myer's Scrutite." The units are mounted on a drilled and tapped mounting plate at the back of the box.

Water Tight (WT) NEMA Box Option. This enclosure consists of a NEMA 4 box construction equipped with three cover-holding screw clamps, one on each of the three non-hinged sides of the box. These enclosures are watertight, in addition to oil and dust tight. Unit mounting and electrical connections are made in the same manner as the OT option enclosures.

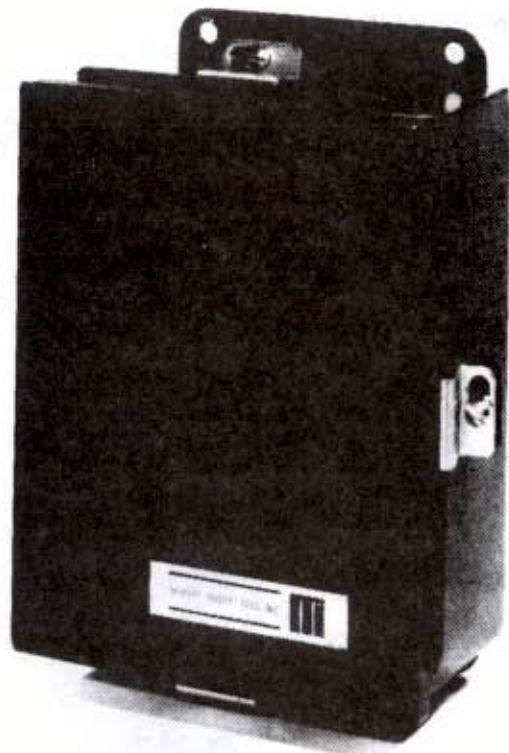

Unit in Water Tight (WT) Enclosure

Fiber Glass (FG) Option Enclosures. This enclosure is molded from pigmented polyester resins, using 302 stainless steel for all exposed hardware. A one-piece neoprene jacket provides additional sealing protection against corrosive environments. Boxes are normally hinged on the long side. The cover is secured by four slot-head screws accessible at the top of the cover and located on each side of the top and bottom cover corners opposite the hinge side. Conduit holes may be cut with a hole punch, and special precautions must be taken with ground connections, since the box material is non-conductive. Refer to Section 3 for wiring information. Units are mounted into the enclosure in the same way as in the OT enclosures.

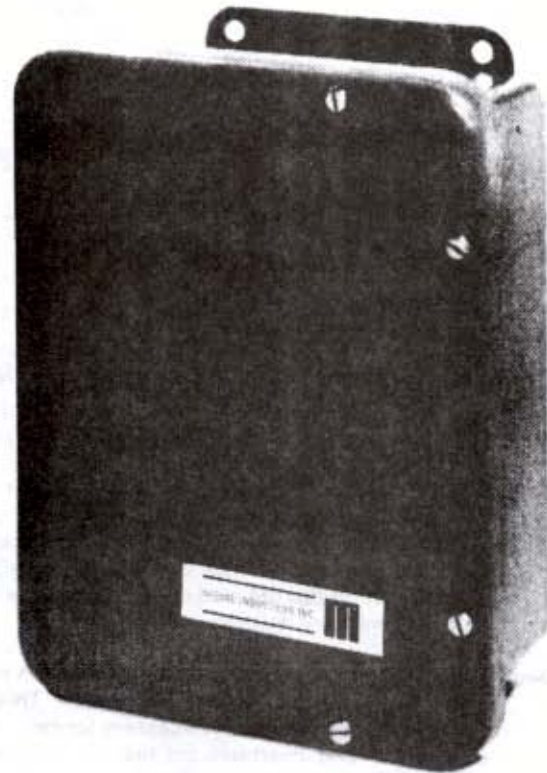

Corrosion Resistant Fiber Glass (FG) Enclosure

General Purpose (GP) Options Enclosures. This enclosure consists of a general purpose steel construction box with knock-outs for various size electrical conduits ($\frac{1}{2}$, $\frac{3}{4}$, or 1 inch). The cover is hinged and spring locked. Units are secured into the enclosure on four studs and four 10-32 nuts.



General Purpose (GP) Enclosure

SECTION 1

GENERAL INFORMATION

The complete enclosure can be secured through four mounting holes provided on the box back cover.

1.3.2 Plug-In (PC) Units Description

The plug-in unit is electrically similar to the EC enclosure. The printed circuit board is keyed to identify the unit and ensure proper connection mating. The other end of the main board is fastened to a display panel that allows external access to the various controls for the unit. A removable plastic safety cover protects the printed circuit board and components from normal environmental hazards. When the PC unit is purchased alone, the user must provide a 15 pin connector, such as Viking part No. ZVK155/1-2 or equivalent. Several mounting options are available for the plug-in unit.

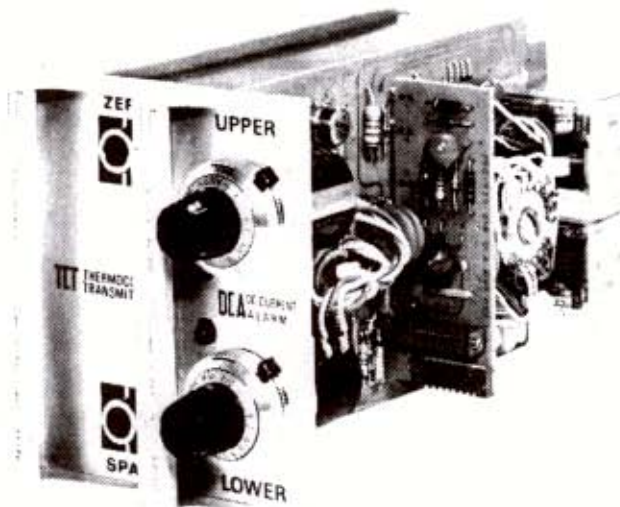

Plug-In (PC) Unit

Rack Mounted (RMR) Card Racks. These enclosures are designed to flush-mount in standard 19 and 24-inch relay racks, respectively. The enclosures are provided with standard EIA hole patterns. Eleven and fifteen position RMR racks are available. These are pre-wired from the module PC connector to the screw-type barrier strip, which are rear-accessed for rack-wiring convenience. All power connections from the PC connectors are bussed together to a separate 3 terminal barrier-strip for external power input. DC power supplies are available. Electrical connections to the card rack are detailed in Section 3, Installation and Operation. Modules are front loaded and a dust cover is provided to minimize the

effects of environmental hazards. Module connectors are keyed to assure that units are plugged into their proper position; keying, however, may be altered in the field if the system configuration changes. Filler cards are available for positions not used by a module.

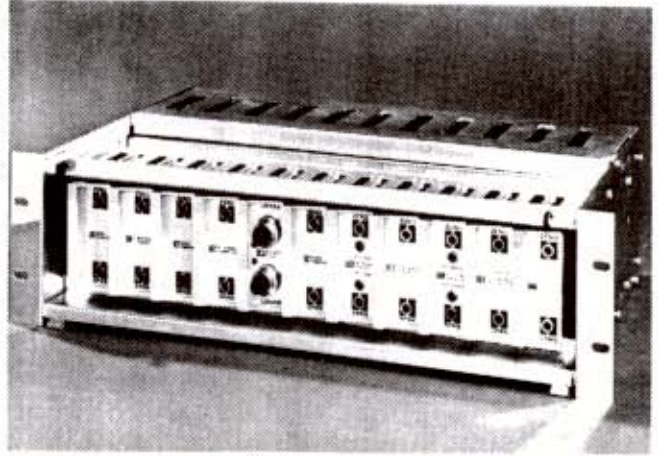

Card Rack Enclosure for Relay Racks (RMR)

Surface Mounted (SMR) Card Rack. These rack enclosures are designed to accommodate as few as five and up to 15 modules. Mounting flanges are located in the rear of the side panel which allows for surface mounting or for NEMA box mounting. These enclosures are electrically identical in construction to the RMR racks. Terminal strips for external connections, however, are front-accessed for wiring convenience whenever the rack is mounted into a NEMA box or against a wall.

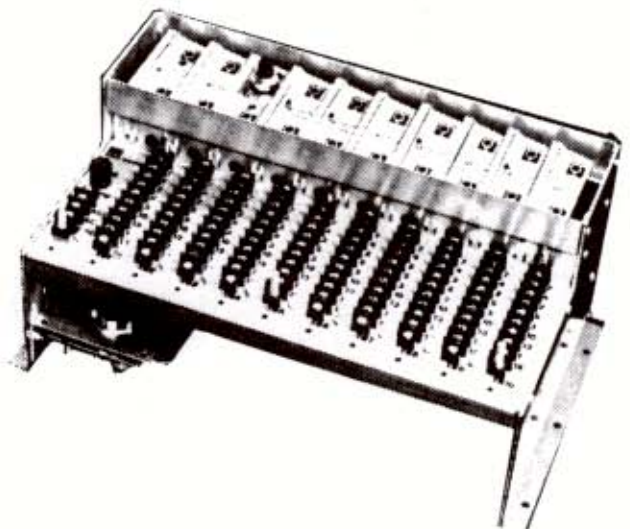

Surface Mounted Card Racks (SMR)

SECTION 1

GENERAL INFORMATION

1.4 SPECIFICATIONS

The specifications for the unit are listed in Table 1-1.

1.5 MODEL NUMBER EXPLANATION AND USE

MOORE INDUSTRIES' model numbers describe an instrument's type, functional characteristics, operating parameter, and include option identification. If all accompanying documentation of a unit is missing, the model number may be used to obtain technical information on the unit by following the example of Table 1-2. Model numbers for units equipped with a terminal strip can be found on the top face of the plastic cover support, nearest the controls. Refer to Section 3, Figure 3-1 for an illustration of the location of this information.

Plug-in units have their model number labeled on the inside of the grip extension to the front panel. PB units have the model number on top of the transmitter case. For explosion-proof units, the

model number is stamped on a stainless steel tag on top of the enclosure and on the identification label on the unit within the enclosure. PM units model numbers are stamped on a stainless steel tag, visible when the rear safety cover is removed. To expose the model number on all NEMA box enclosures, open box and remove safety cover of the unit.

1.6 SERIAL NUMBER USE AND LOCATION

A complete history is kept on every MOORE unit. This information is keyed to the serial number. Whenever service data is required on a unit, it is necessary to provide the factory with a serial number as well as a model number. This identification is usually located on bottom plastic caution cover support. Plastic cover must be removed in order to see the serial number of the unit, except for plug-in units and explosion proof where the serial number is engraved into the PC board or stamped on a stainless steel tag respectively, and is usually preceded by the letter E.

TABLE 1-1. UNIT SPECIFICATIONS

INPUT:

Current:

- 1-5 mA into 200 ohms nominal
- 4-20 mA into 50 ohms nominal
- 10-50 mA into 20 ohms nominal

Voltage:

- 1-5V standard, 0-1V, 0-5V, 0-10V, 1 megohm minimum input impedance. Other voltages optional.

FRONT PANEL ADJUSTMENTS: Adjustable with multi-turn potentiometer

Span (Current & Voltage Input): With full scale input, adjusts output to 100% \pm 25% of selected output span.

Zero (Current & Voltage Input): With minimum input, adjusts to 0% \pm 10% of selected span.

OUTPUT: Operational amplifier feedback current source; output limited to 150% of maximum output range value.

Current:

- 1-5 mA into 4800 ohm load
- 4-20 mA into 1200 ohm load
- 10-50 mA into 480 ohm load

Voltage: 1-5V DC standard at 0.25 mA DC maximum.
Ripple: 20 mV P/P at maximum span and maximum load resistance.

Load Effect: \pm 0.01% of span from 0 to maximum load resistance (current output).

PERFORMANCE:

Calibration Capability: \pm 0.2% of span (linearity and repeatability)

Ambient Temperature:

Range: +32°F to +160°F (0°C to +70°C)

Effect: \pm 0.02%/°F over above range

Isolation: Voltage output units have input negative side common to output negative side. Current output models have output negative side elevated above input negative side (true current source). Power input isolation is maintained on both AC and DC powered units.

POWER INPUT:

24V DC, \pm 10% 45V DC \pm 10% or 117V AC, 220V AC, 50/60 Hz \pm 10% standard. 5 watts maximum.

Line Voltage Effect: AC or DC: \pm 0.005%/1% line change.

TABLE 1-2. MODEL NUMBER EXAMPLE

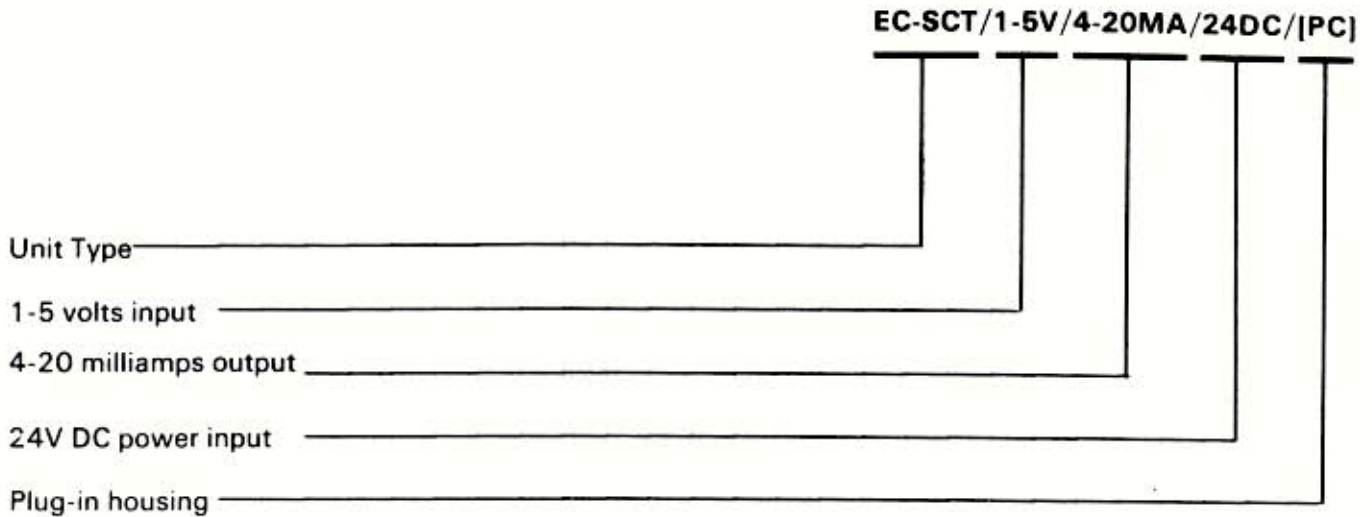

TABLE 1-3. UNIT ELECTRICAL OPTIONS

OPTION DESCRIPTION	CODE
Zero elevation — required on all transmitters for inputs exceeding standard zero adjustment capability (specify input for 0% out)	EZ
Reversed input/output current or voltage relationship	RO
High-Current/Voltage Output — 0-1V, 0-5V, 1-5V, and 0-10V output, capable of delivering 20 mA	HI
Selected Current Output — provides external selection of different current outputs (1-5 mA, 4-20 mA, or 10-5 mA)	SC

CALIBRATION

2.1 GENERAL INFORMATION

This section provides information about unit calibration. Units with standard input and output levels are normally calibrated at the factory. After the unit is unpacked, general operating level checks of units is recommended. Usually these checks, specified in this section under calibration procedures, require little or no adjustments. If units are ordered with factory calibration option (FC), an exact calibration is performed at the factory. Adjustments should not be made in the field on these units unless a new range of input or output signal level is desired.

2.2 CONTROLS DESCRIPTION AND LOCATION

The controls consist of ZERO and SPAN adjustments, located on the unit front panel. External controls are multiturn potentiometer that are adjusted with a blade screwdriver.

CAUTION

USE BLADE SCREWDRIVER NOT MORE THAN 0.1 INCH (2.54 mm) WIDE. USE OF A WIDER BLADE MAY PERMANENTLY DAMAGE THE POTENTIOMETER MOUNTING.

This type of potentiometer usually requires 20 turns of the shaft to move the wiper from one end of its range to the other. It is equipped with a slip clutch at either end of its travel to prevent damage if it is turned beyond the wiper stop. Usually a slight change in feel will be noticed when the clutch is slipping. However, if this change is not observed, either end can be reached by turning the shaft 20 turns in the desired direction. Controls are connected, so turning the shaft clockwise increases the quantity or makes it more positive, and turning the shaft counterclockwise has the opposite effect.

2.3 TEST EQUIPMENT AND TOOLS REQUIRED

Test equipment and tools required for calibration of the unit are described in Table 2-1; they are not supplied and must be provided by the customer at the installation or test site.

2.4 TEST EQUIPMENT SETUPS

Off-line calibration for all units require the same test equipment setups regardless of option or physical configuration. The hookup requirements and physical preparations may vary on some units. The following paragraphs define the general test

TABLE 2-1. TEST EQUIPMENT AND TOOLS REQUIRED

Equipment or Tool	Characteristic	Purpose
Screwdriver (blade)	Blade not wider than 0.1 inch (2.54 mm)	Front panel control adjustment
Adjustable DC Signal Source	Must be accurate to within $\pm 0.05\%$ or better	Simulates input signal
DC Voltmeter	Must be accurate to within $\pm 0.05\%$ or better	Output signal monitoring (voltage outputs only)
DC Milliammeter	Must be accurate to within $\pm 0.05\%$ or better	Output signal monitoring (current outputs only)

setup and identify the units that require special attention for test preparation and connections.

2.4.1 General Test Equipment Setups

The test equipment setup required for calibration of all units is identical except for connection identification.

2.4.2 Plug-In Units Test Equipment Setup

Plug-in units equipment test setup is the same as the one shown in Figures 2-1 and 2-2, except that printed circuit board connections are identified in that figure by numbers in parentheses. Connection identification numbers are etched in the component side of the PC board. Plug-in units inserted in a rack also use the test setup shown in Figure 2-1 with card rack terminal connections identified by numbers in parentheses. These include either the rack mount (RMR) or the surface mounted (SMR).

2.4.3 Explosion-Proof (EX) and PT Option Test Setup

Figure 2-2 shows the general test setup configuration for an explosion-proof enclosure or a PT option. Note that in the explosion-proof configuration the protective housing must be opened and the unit removed to expose the connection block. Similarly, units with the PT configuration must be unplugged from the connection block in order to access the connections more effectively. Numbers in parentheses refer to terminal block numbers.

2.5 CALIBRATION OF UNITS

Units are calibrated and checked for proper performance at the factory before they are shipped. However, unless calibration was requested to a specific set of input-output values, the unit performance should be checked by the user before the unit is placed in service. Calibration consists of simulating the operative signal input and adjusting the unit to obtain the specified output.

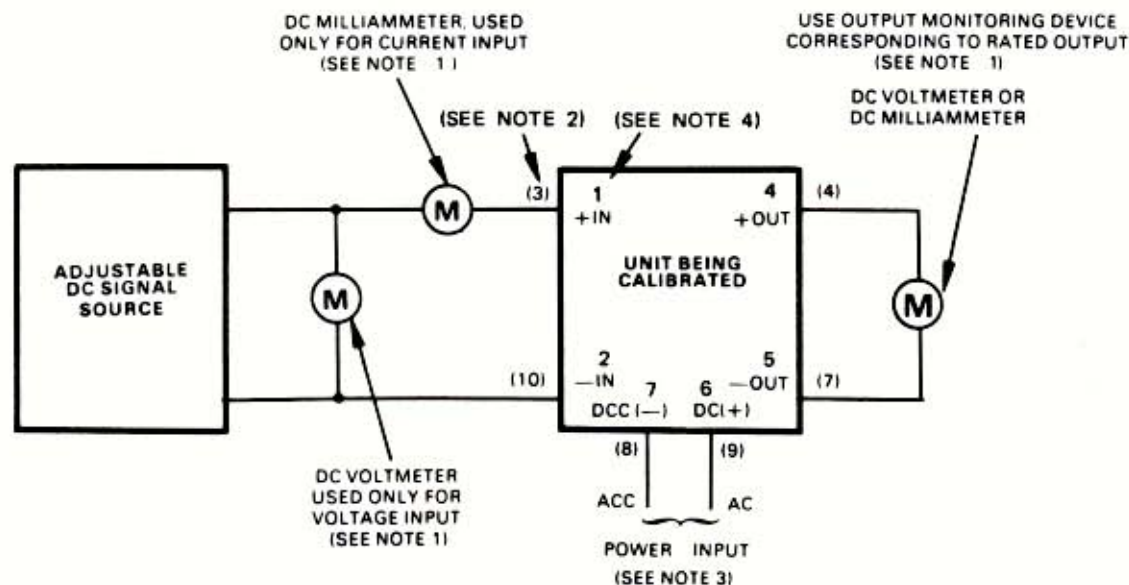

NOTES:

1. INPUT AND OUTPUT MONITORING DEVICES MUST BE ACCURATE TO WITHIN +0.05% OR BETTER
2. NUMBERS IN () APPLY TO PLUG-IN UNITS ONLY
3. EITHER AC POWER OR DC POWER IS SUPPLIED, BUT NOT BOTH
4. NUMERALS INSIDE UNIT OUTLINE REFER TO TERMINAL POSITIONS (see Figure 3-9)

Figure 2-1. Test Equipment Setup For Calibration of Unit

SECTION 2

CALIBRATION PROCEDURES

NOTE

Refer to paragraph 1.5 for information on how to use the model number to obtain the specified values of minimum and maximum inputs and outputs.

- c. Adjust the input signal source to the value of the minimum input signal that will be applied to the unit (0V DC, 1 mA, 4 mA, 10 mA, 1V DC, or whatever the *minimum* input signal will be).
- d. Adjust the ZERO potentiometer to obtain 0% output (1 mA, 4 mA, 10 mA, 1V DC, or whatever the 0% output is) with the minimum input signal applied as in step (c).
- e. Adjust the input signal source to the value of the maximum input signal that will be applied to the unit (1V DC, 5 mA, 20 mA, 50 mA, 5V DC, or whatever the *maximum* input signal will be).
- f. Adjust the SPAN potentiometer to obtain 100% output with the maximum input signal applied as in step (e).
- g. Repeat steps (c) through (f) until no further adjustment of either the ZERO or SPAN potentiometer is required.
- h. Apply 0% input plus 25%, 50%, and 75% of the span successively and check that the output is linearly proportional (within $\pm 0.2\%$ of the span).
- i. After step (h) has been successfully completed, remove the input signal and then turn off the power input to the unit.

INSTALLATION AND OPERATION

3.1 MECHANICAL INSTALLATION

Units may be obtained in various physical configurations. Figures 3-1 through 3-9 show the outline dimensions and other installation requirements for the available configurations. Select the proper outline and dimension figure applicable to the unit purchased. Be sure to observe the applicable special procedures and precautions given with the illustration. Although the units are designed to operate in free air at quite a high am-

bient temperature, it is advisable, if possible, to mount the unit on a surface made of material that can serve as a heat sink. For a plug-in unit mounted in a rack, be sure that the rack has adequate ventilation.

3.2 ELECTRICAL CONNECTIONS

All electrical connections to units (except plug-in) are made to the terminal block on the unit. On plug-in units, the electrical connections are made

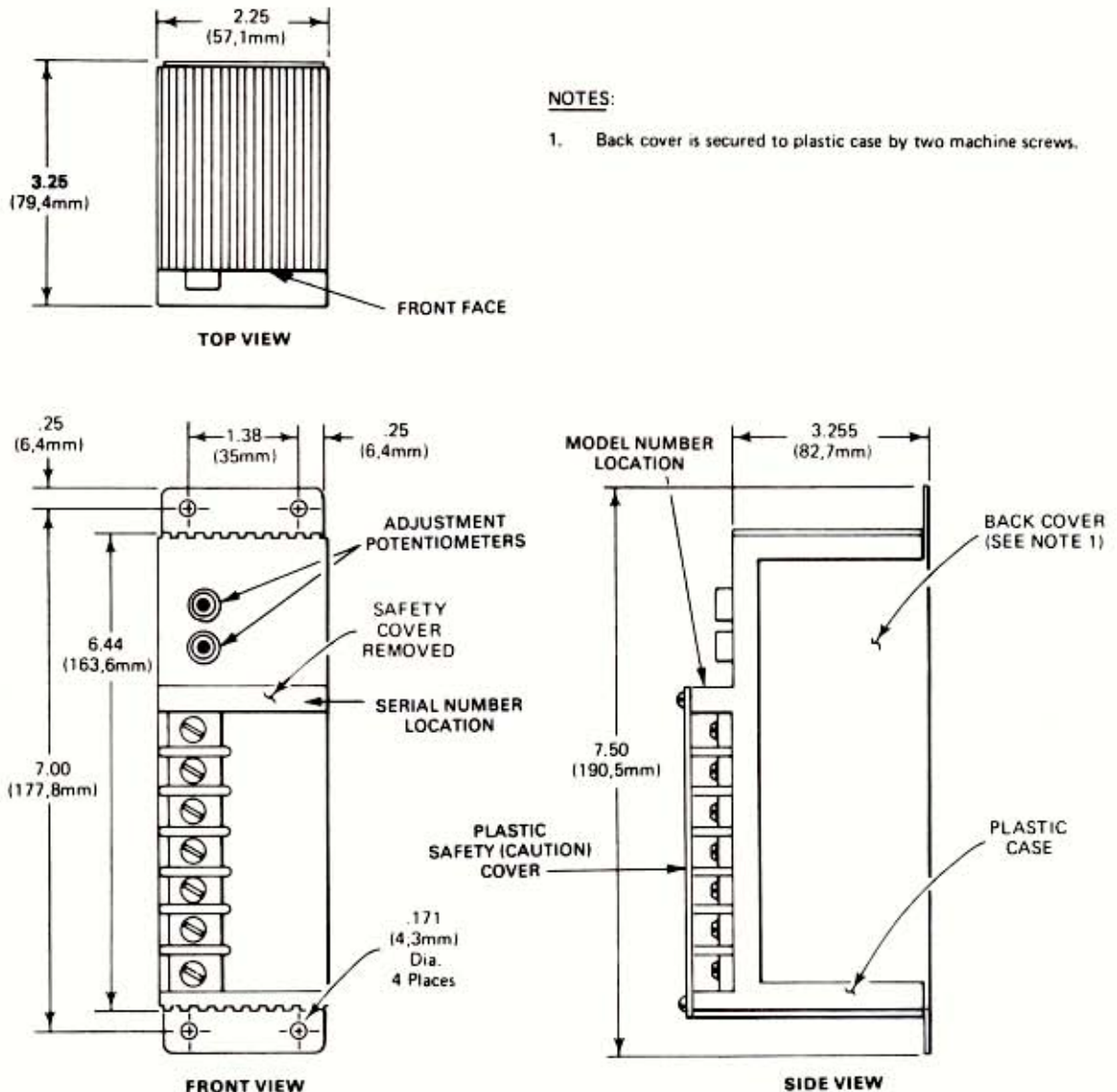

NOTES:

1. Back cover is secured to plastic case by two machine screws.

Figure 3-1. EC Enclosure, Outline and Dimensions

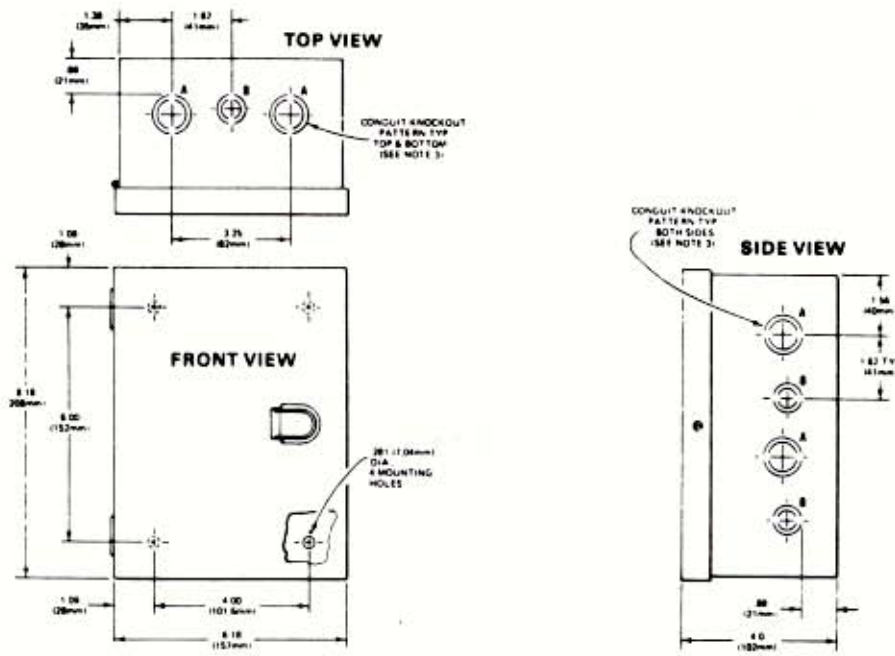

NOTES:

1. Complete Model No. and Serial No. are located on identification bracket at upper end of terminal blocks.
2. Wire routing to terminal blocks is provided by open lower end of safety cover. Terminal blocks (2) accommodate #6 screw lugs.
3. Conduit knockouts are for conduit sizes as follows: A = $\frac{3}{4}$ - 1; B = $\frac{1}{2}$ - $\frac{3}{4}$.

a. General Purpose (GP) Enclosure

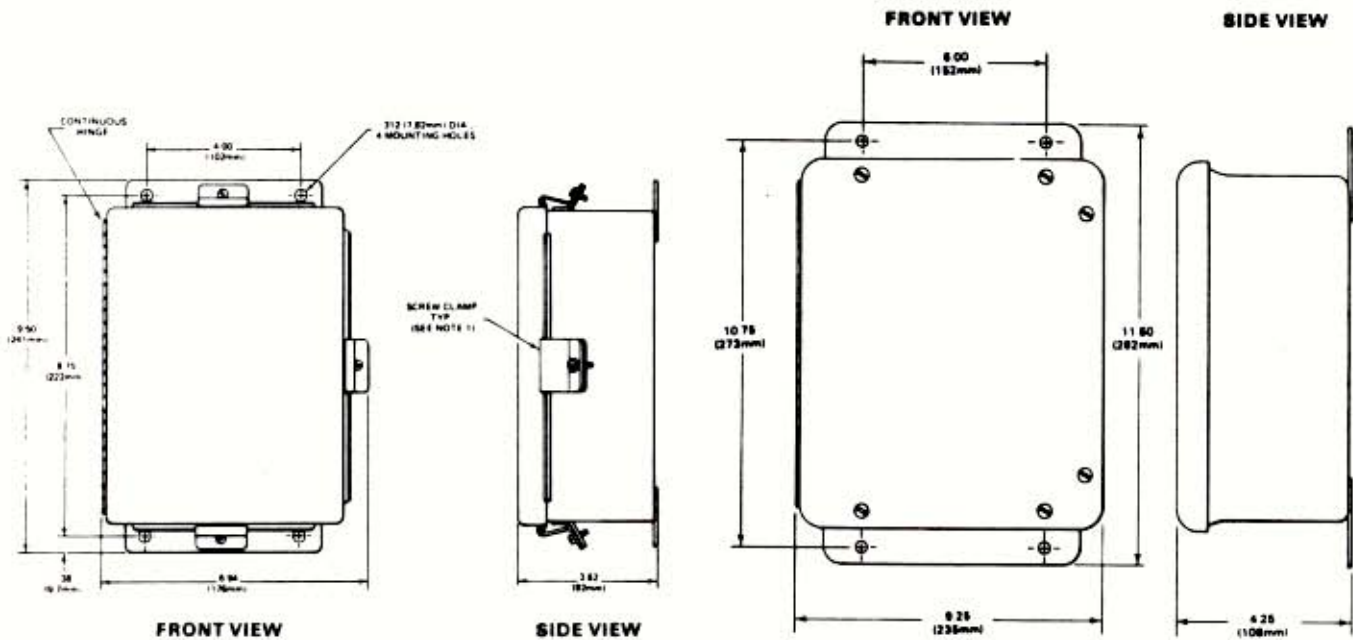

NOTES:

1. NEMA 4 enclosure is shown. NEMA 12 is similar except that two screw clamps are on right side and there are none at top and bottom.
2. NEMA 12 enclosures are only oil and dust tight, whereas NEMA 4 enclosures are also water tight.
3. Wiring access to terminal blocks is provided by open lower end of safety cover.

NOTES:

1. All exposed metal hardware is type 302 stainless steel. Boxes are hinged on the long side unless otherwise specified.
2. All boxes include a one piece closed cell neoprene gasket.
3. Standard color is machine tool grey. Boxes are molded from pigmented polyester resins with the color throughout the box wall for a maintenance-free installation.

b. Water and Oil-Tight (WT/OT) Enclosures

c. Corrosion-Proof (FG) Enclosure

Figure 3-2. Standard Unit in NEMA Boxes, Outline and Dimensions

SECTION 3

INSTALLATION & OPERATION

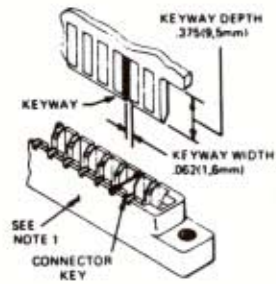
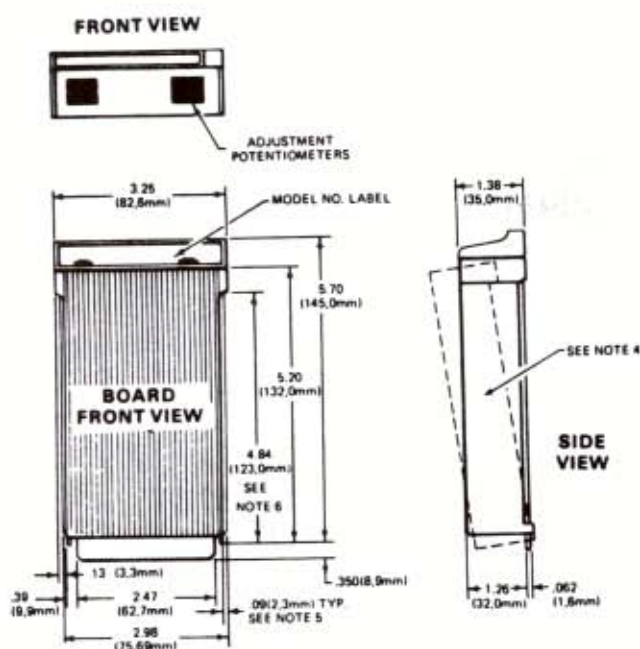

- NOTES:**
1. Connectors used must have contacts on 156 (3.96mm) centers, with contacts for both surfaces of board (recommended type, Viking part no. 2VK155/1-2).
 2. Maximum card insertion depth in connector is 350 (8.89mm).
 3. Minimum width of connector insertion slot is 2.470 (62.70mm).
 4. Removable plastic safety cover, 2.800 (71.12mm) wide.
 5. Maximum card edge-guide insertion depth is .09 (2.29mm). Guides must be non-conductive.
 6. Card edge-guides cannot extend beyond here.
 7. Card extender part no. 350-513-00 is available for testing unit while in operating position.

Figure 3-3. Plug-In Unit, Outline and Dimensions

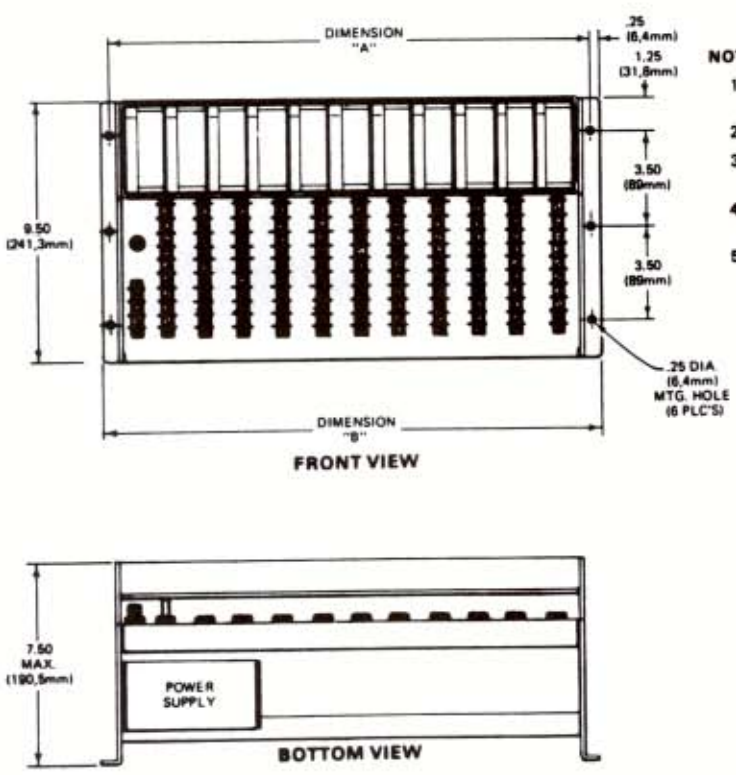

- NOTES:**
1. M.I.I. surface mounted card rack accommodates as few as 5, and as many as 15 plug-in units.
 2. Empty positions may be closed by means of filler cards. P/N 350-213-00.
 3. Connections are keyed to assure units will be plugged into proper position. Keying may be changed in the field if the system configuration changes.
 4. Eleven position card rack is illustrated. Dimensions for mounting larger or smaller racks may be found in the table.
 5. 24V power supply, shown, is capable of powering all models in card rack. Input specification, 117 VAC \pm 10%, 50/60 Hz, approximately 40 watts.

NUMBER OF POSITIONS	DIMENSION			
	A		B	
	mm	mm	mm	mm
5	9.19	233.4	9.89	246.1
6	10.62	269.7	11.12	282.4
7	12.06	306.3	12.56	319
8	13.50	342.9	14.00	355.6
9	14.94	379.5	15.44	392.2
10	16.38	416	16.88	428.8
11	17.81	452.4	18.31	465
12	19.25	489	19.75	501.7
13	20.69	525.5	21.19	538.2
14	22.12	561.8	22.62	574.5
15	23.56	598.4	24.06	611.1

Figure 3-4. Surface Mounted Card Racks (SMR), Outline and Dimensions

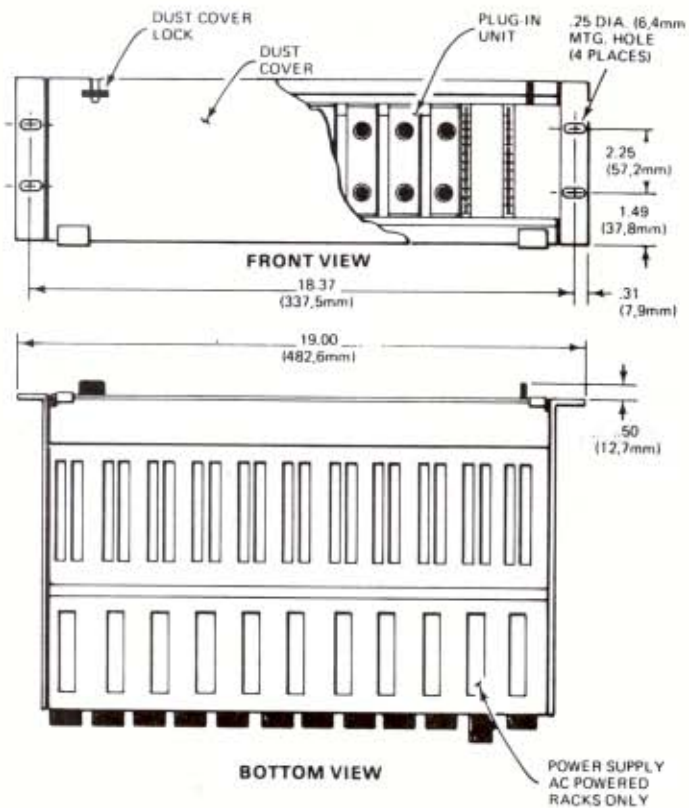

NOTES:

- 1 Connectors are keyed to assure units will be plugged into proper position. Keying may be changed in the field should the system configuration change.
- 2 This enclosure is designed to mount in a standard 19-inch rack with E.I.A. hole pattern.
- 3 Surface mounting card racks for use in NEMA type enclosures are also available. Contact factory for further details of card racks and card rack assemblies.
- 4 Barrier strip connectors are CSA approved.
- 5 Empty positions may be closed by means of filler cards, Part No. 350-213-00, which must be ordered individually in quantity required.
- 6 24 volt power supply furnished capable of powering a typical complement of up to fifteen modules. Input specification 117 volts \pm 10% 50/60 Hz approximately 40 watts.

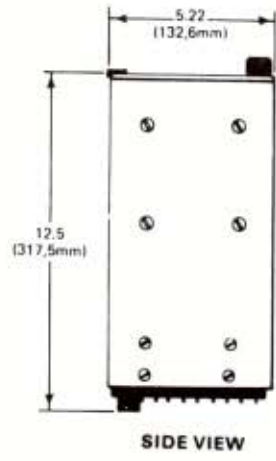

a. Eleven-Position Card Rack

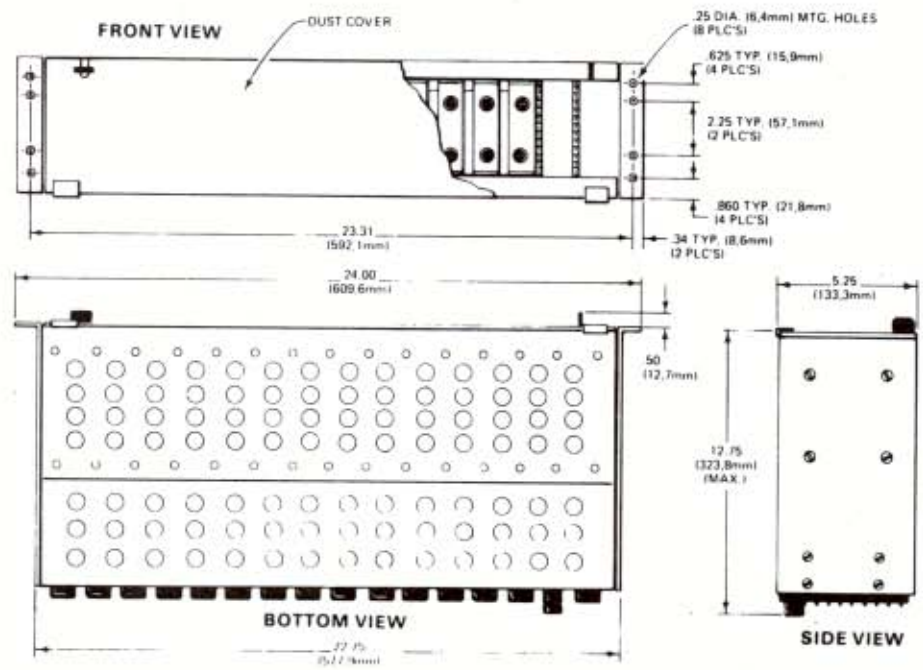

b. Fifteen-Position Card Rack

Figure 3-5. Rack-Mounted Card Racks (RMR) Enclosure, Outline and Dimensions

to terminals on the mating connector for the unit. Terminals used for units and their options are defined in the following paragraph.

3.2.1 General Wiring Information

No special wire or cable is required for signal connections to the unit. To avoid transients and stray pickups, it is recommended that twisted conductors be used where they are run close to other services (such as power wiring). Electrical connections to the units fall into two major categories: connections to units with terminal blocks and connections to plug-in units and their associated enclosures.

Wiring Information For All Units With Terminal Strips and Blocks. Units with terminal strips or terminal blocks have terminals supplied with 6-32 screws long enough to easily accommodate three spade-lug connectors. Dress all wiring to and from the terminals along the connecting edge of the unit. Spade lug connectors are recommended for all wire terminations. Figure 3-6 illustrates the terminal strip locations. Table 3-1 provides the complete labeling nomenclature for EC units and any available electrical options. Terminal labeling appears next to the terminal it identifies on units with terminal strips.

Wiring Information For All Units in NEMA Boxes. Units mounted in NEMA boxes are terminal strip units with or without the options listed in Table 3-1. NEMA boxes for OT or WT options do not have conduit holes fittings or knockouts. Conduit access must be provided by fittings such as Myer Scru-Tite or equivalent.

General Purpose (GP) enclosures have conduit knockouts for various sizes of conduits from 1-inch down to 1/2-inch. Corrosion-Proof (FG) enclosures require special attention with ground connections. Since enclosure material is polyester resin, conduit cutouts may be cut with a punch or hole saw. Ground continuity may be obtained in two different ways. If a metal panel is used, ground can be made between the metal conduit locknut and the panel at enclosure entry and exit. If the enclosure is used without the back panel, a jumper between the conduit entry and exit is necessary to maintain ground continuity. Remove screw-on plastic cover to access terminal strips.

Wiring Information for Plug-In Units. Plug-in units and card rack electrical connections are made to terminals on the mating connector for the unit or the card rack terminal strips. Figure 3-7 illustrates the terminal strip connections and their numerical reference designator. Table 3-2 provides a complete terminal nomenclature for both Plug-In and Rack assemblies.

3.2.2 Connections On Units With SC Option

On units with the SC (selectable current) option, connect the input selectable current resistor to the +IN and - terminals. Connect the output selectable current resistor to the terminals marked SC, or those specified in Table 3-1. The current range is marked on the body of each resistor. If provided, the selectable current resistors for a plug-in unit should be mounted externally either at the terminal block of the card rack, or soldered to the appropriate terminals on

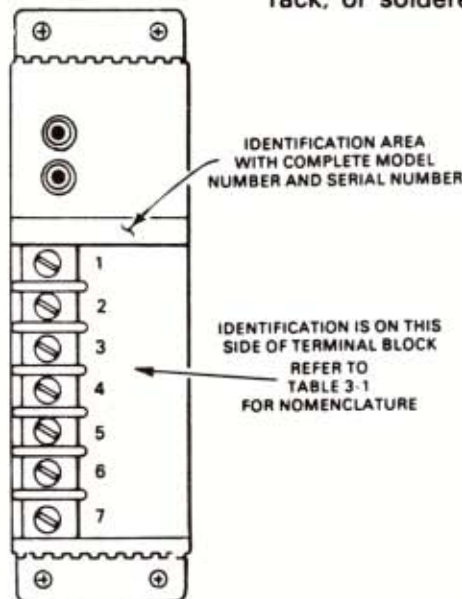

Figure 3-6. Terminal Strips and Terminal Blocks Identification

TABLE 3-1. TERMINAL NOMENCLATURE FOR EC ENCLOSURE UNITS

Options	Terminal Positions (See Figure 3-6)						
	1	2	3	4	5	6	7
NONE	+IN	-IN		+OUT	-OUT	DC	DCC
AC	+IN	-IN		+OUT	-OUT	AC	ACC
SC (Output)		SC	SC				
SC (Input) (See Note)							

NOTE: SC input resistor is mounted across \pm IN terminals.

Legend: \pm IN Signal Input DC +DC Power Input
 AC AC Power Input DCC -DC Power Input
 ACC AC Power Input Return \pm OUT Signal Output

the PC connector. See Table 3-2 for correct connections.

3.2.3 Power Connections

Units are designed to operate from either a DC or AC power source. Refer to paragraph 1.5 for information on how to use the model number to determine the type of power required.

DC-Powered Units. On these units the DC terminal is connected to the + (positive) side of the source, and the DCC terminal is connected to the - (negative) side. The DC source should be regulated to within $\pm 10\%$ of the nominal voltage and should be capable of delivering 5 watts.

AC-Powered Units. These units require 117 volts AC $\pm 10\%$, 50/60 Hz at 5 VA of nominal power or

TABLE 3-2. CONNECTOR PINS AND TERMINAL ASSIGNMENTS FOR PLUG-IN UNIT AND CARD RACKS

Options	Terminal Position (See Figure 3-7)														
	1	2	3	4	5	6	7	8	9	10	11	12	13	14	15
NONE			+IN	+OUT			-OUT	DCC	DC			-IN			
SC (Input)	(SEE NOTE)														
SC (Output)															SC

NOTE: SC input resistor is mounted across \pm IN terminals.

Legend: DC +DC Power Input +IN Signal Input
 DCC -DC Power Input \pm OUT Signal Output

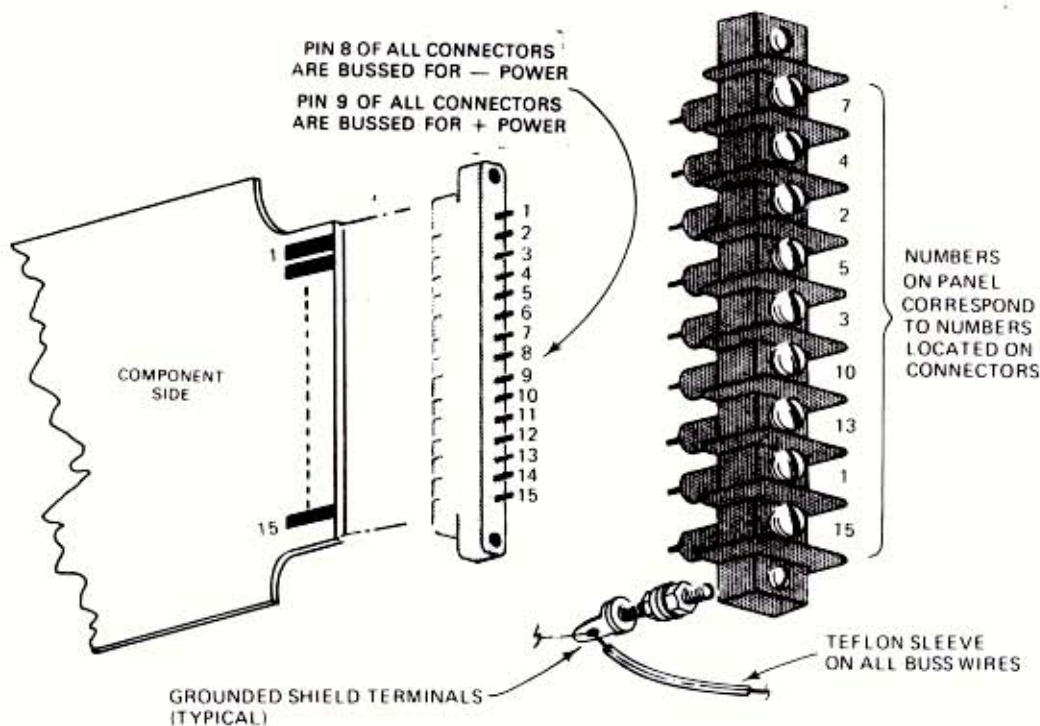

Figure 3-7. Plug-In Connectors and Terminal Strips Wiring and Identification

220 or 240V AC optionally. The AC terminal should be connected to the ungrounded or "hot" side of the supply, if possible, and the ACC terminal is connected to the common or neutral.

Rack Power Connections. Connect power input wires to the appropriately labeled terminals of the 3-terminal connector strip. The third terminal on strip is chassis ground.

3.3 OPERATION AND PERIODIC OBSERVATION

Once calibrated and installed, the unit may be operated unattended. The only controls on the outside of the unit are the SPAN and ZERO potentiometers, which, after initial adjustments, need no

further attention. There are no indicators on the unit. Because the circuit uses highly reliable solid-state components with no moving parts, the unit should operate virtually maintenance-free for a long period of time. However, if a malfunction should occur, refer to Section 5 for maintenance information.

A periodic check of input and output connections is recommended every six months to ensure continued dependability of operation.

A unit may become warm during operation, especially where the ambient temperature is rather high. This is perfectly normal and should not be a cause for alarm unless a malfunction is also observed.

THEORY OF OPERATION

4.1 INTRODUCTION

This section describes the theory of operation of the unit. The description of each circuit is presented in sufficient detail so that if troubleshooting is required, it may be carried out intelligently and rapidly.

A schematic diagram (146-403-00) and a block diagram (Figure 4-1) of the module is included in

this manual. Unless otherwise directed, refer to the schematic diagram in Section 6, when reading the following paragraphs.

Components reference designators are listed here for both the standard and the plug-in models. The standard unit reference designator is listed first followed by the reference designator for the plug-in unit in parentheses and italics. If both reference designators are the same, only one is listed.

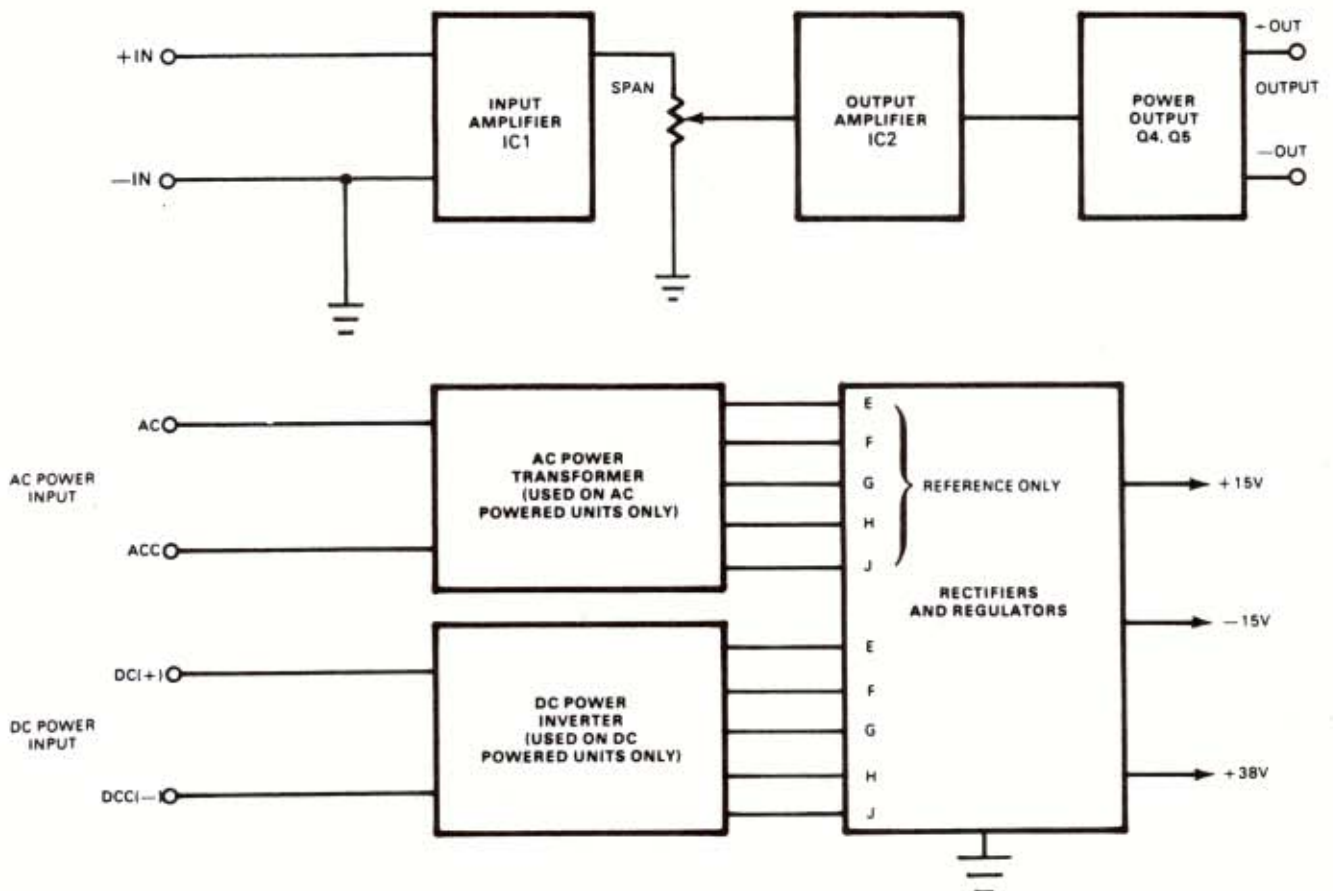

Figure 4-1. EC-SCT Block Diagram

4.2 GENERAL FUNCTIONAL DESCRIPTION

The EC-SCT consists of the functional elements illustrated in Figure 4-1. This figure also shows both an AC operated power supply and a DC operated supply. A unit contains either the AC or the DC source but not both.

The unit amplifies the applied DC input signal to produce a DC output proportional to the input. High stability is achieved by using operational amplifiers with large amounts of feedback. A variation in the output circuit allows the unit to produce either current or voltage output. Although no isolation is provided for the signal from input to output, there is isolation between power input and the signal processing circuits.

4.3 DC POWER SUPPLY

When a unit is ordered for use with DC power, a DC-DC converter is used instead of the power transformer T2 shown on the schematic diagram. The applied DC power is converted to a square wave by transistors Q1 and Q2 and transformer T1. The switching frequency is approximately 16 KHz. Inductor L1 and capacitor C13 filter the DC line to prevent any feedback ripple from being injected back to the DC input source. The transformer secondary voltages are rectified, filtered and regulated for the internal operating voltages.

4.4 AC POWER SUPPLY (Not in PC Unit)

When AC power is applied, the power supply produces AC voltages of different amplitude (with respect to ground). These are applied to the rectifier and regulator, which develop regulated and unregulated DC as operating voltages for the unit.

The AC power supply circuit consists of a power transformer that produces two different AC outputs. Each half of the center-tapped secondary of T2 produces 24 volts. The other secondary produces 36 volts. The voltage from the center-tapped secondary is applied to points E, F, G of the rectifier and regulator circuits. The voltage from the other secondary is applied to points H, J of the DC supply. Operation of the power supply is identical to that described in paragraphs 4.3 and 4.5.

4.5 RECTIFIER AND REGULATOR CIRCUIT

The rectifier and regulator circuit processes the output of the transformer secondary and converts the signal to regulated DC. The 13-14 secondary of T1 supplies the high voltage for the current out-

put stage through a bridge consisting of 4 diodes CR1 through CR4 and filter capacitors C11 (C5), C15 (C2). The other secondary is center-tapped, full-wave rectified by diode bridge CR5 (CR9), thru CR8 (CR12) and becomes the input to a dual tracking voltage regulator VR1 that generates an output of $\pm 15V$ (points A and B). Capacitors C5 (C9), C6 (10) provide output filtering for this supply.

4.6 INPUT AMPLIFIER

The input amplifier circuit consists of operational amplifier IC1 (IC2) and associated circuits. The input signal at +IN is filtered by R9 (R24), R14 (R25) and C3 (C13). IC1 is connected in a non-inverting unity gain configuration (R13 omitted). When a current input signal is processed by the EC-SCT, resistor R11 (R21) converts the input current signal to a voltage signal. If SC input option is selected, R11 (R21) is replaced by the externally mounted resistor R101.

4.7 OUTPUT AMPLIFIER

The output amplifier circuits consist of IC2 (IC1), the SPAN and ZERO controls and associated components. Normally the output of IC1 is divided-down by R1, SPAN control, and R4. Portion of this output is tapped at the wiper of the SPAN potentiometer and fed to IC2 (IC1) non-inverting input through R21 (R6). Resistors R22 (R8) and R23 (R7) are not used in this configuration. Zero circuit consisting of ZERO control and R5 (R17) through R8 (R20) provide the signal necessary to effect the inverting input of IC2 to obtain the correct output for 0% input. This zero offset signal is obtained by a resistive divider across the +15V power supply. Since the ZERO control is in the electrical center of the network, a small movement of the ZERO control wiper will shift the signal to either a positive or negative value. Since the signal is applied to the inverting input to IC2, the level shift will affect the IC2 output in a reverse manner.

When the RO option is selected, IC1 (IC2) output is divided-down by R2, SPAN control and R3 (R4). The signal from the SPAN control is fed to IC2 (IC1), inverting input through R22 (R8). Resistor R21 (R6) is omitted while resistor R23 (R7) provides a ground reference to IC2 (IC1) non-inverting input. The zero circuit, although derived in the same way as described above, now shifts the signal pedestal into IC2 (IC1) non-inverting input.

4.8 POWER OUTPUT STAGES

The power output stages configuration varies according to the type of unit output selected.

4.8.1 Unit Current Output

When a unit is selected with current output, the output of IC2 (IC1) pin 6 supplies the drive necessary to operate the power output stage. Two transistors Q3 (Q2), Q4 (Q1) are wired in a Darlington pair arrangement with the load in series with the transistors power source. A special power supply is provided for this stage (+38V, point C). Transistor Q5 is a power transistor capable of handling the high output currents in this circuit configuration. Resistor R26 (R15) generates the feedback signal to IC2 (IC1). The resistor value varies according to customer-selected current output ranges. Voltage divider R24, (R11), R25 (R10) is a saturation limitation circuit. The resistance ratio is selected for overload protection and limits the output to 150%. Capacitor C1 (C3) is used to filter the output signal from spurious noise generated from the unit or the transmission lines to the external load.

4.8.2 Unit Voltage Output

When the unit is selected with a voltage output configuration, the output signal from IC2 (IC1) is used as the output drive at the +OUT terminal. Resistors R26 (R13) and R27 (R12) along with R15 (R9) and R10 (R1) from the feedback network of IC2 (IC1). R24 (R11) provides output current limiting.

When the unit is selected with HI option output, the output of IC2 (IC1) drives power transistor Q4 (Q1). Output voltage of the unit is developed across resistors R26 (R13) and R27 (R12). The power to drive Q4 (Q1) is supplied by a special power source (+38V) derived at point C of the power supply (see paragraph 4.5). Voltage divider R24 (R11), R25 (R10) performs the same overload protection described above. Resistors R26 (R15) and R27 (R12) along with R15 (R9) and R10 (R1) from the feedback network of IC2 (IC1).

MAINTENANCE

5.1 INTRODUCTION AND GENERAL INFORMATION

This section contains information to aid in the maintenance of the unit. This includes disassembly instructions for all mechanical options, as well as general troubleshooting. Precautions and special techniques required to replace components are also described.

5.2 DISASSEMBLY

When unit troubleshooting is required, it is first necessary to disassemble the unit. The physical configuration of the unit determines the steps to be followed in disassembly. These are described in the following paragraphs.

NOTE

Always identify wires — usually by tagging — before disconnecting existing connections.

CAUTION

DISCONNECT INPUT SIGNAL AND REMOVE POWER INPUT BEFORE DISASSEMBLING UNIT.

5.2.1 Disassembly of Unit

To disassemble a unit, remove the unit from its installed position. After the unit has been removed from its installed position, disassemble the unit as follows to gain access to the circuit board. Figure 5-1 illustrates this procedure.

- a. Remove the two rear Phillips-head screws that hold the cover to the case.
- b. Slide the case (with the circuit board still attached) free of the cover. Points on the circuit board may now be reached for troubleshooting. It is suggested that the cover be used to hold the removed hardware.

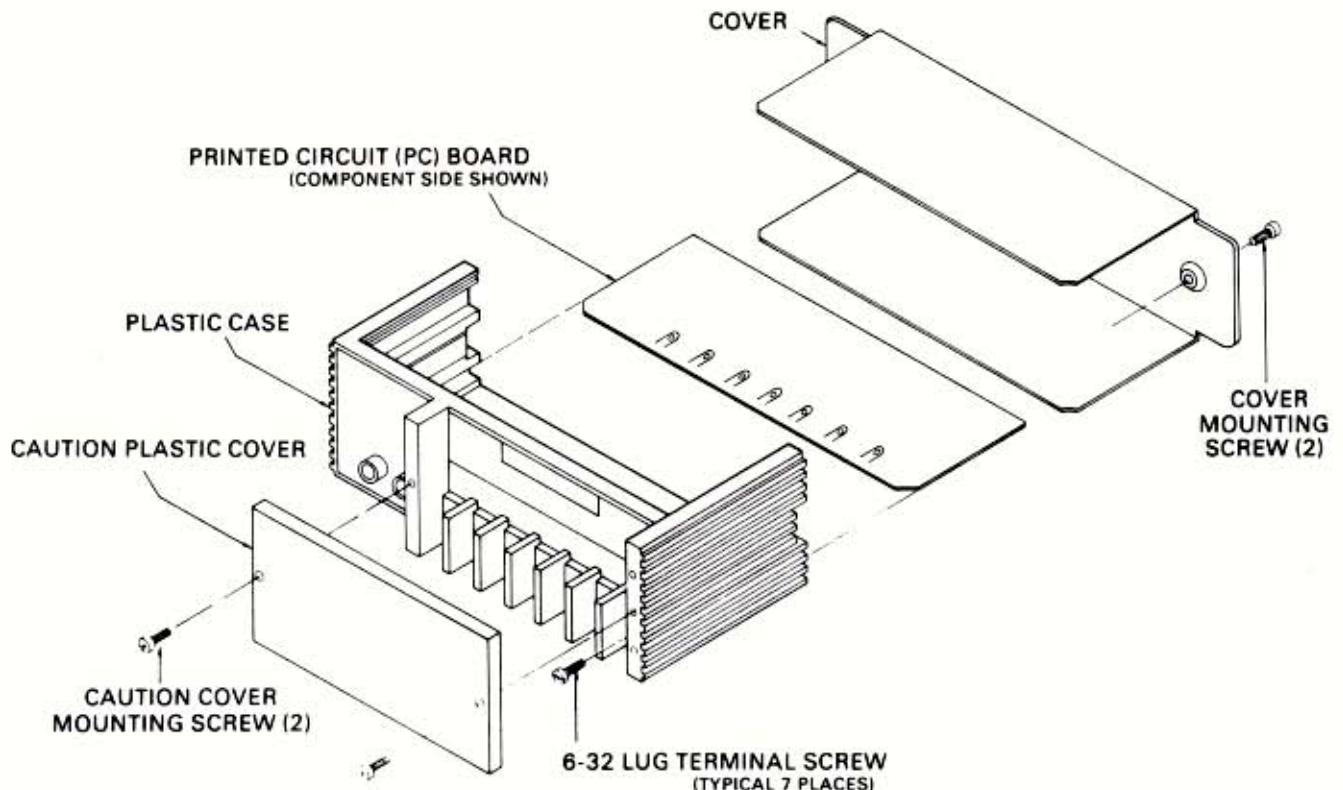

Figure 5-1. Disassembly of EC-Unit

5.2.2 Disassembly of Unit in NEMA Boxes

Normally electrical connections are made to NEMA boxes through conduits. Units are secured on a mounting plate in the NEMA boxes. The following disassembly instructions apply to the various configurations.

Disassembly of Units in OT, WT and GP Enclosures. Use the following procedures to disassemble unit:

- a. Loosen clamps that hold hinged cover on OT and WT enclosures only, and open enclosure.
- b. Loosen and remove two screws that hold plastic safety cover on unit.
- c. Tag and disconnect wires from unit.
- d. Loosen four mounting screws that hold unit into box.
- e. Disassemble unit as described in paragraph 5.2.1.

Disassembly of Units in FG Enclosure. Use the following procedures to disassemble unit:

- a. Loosen four screws that secure cover on box.
- b. Open box and inspect gasket for damage. Replace if necessary.
- c. Remove plastic safety cover from unit.
- d. Tag and disconnect wires from unit.
- e. Tag and disconnect ground wire from conduit to mounting post.
- f. Remove four nuts that secure unit to mounting plate in rear of box.
- g. Disassemble unit as described in paragraph 5.2.1.

5.2.3 Disassembly of a Plug-In Unit

To remove the cover of a plug-in unit, proceed as follows:

CAUTION

DO NOT LIFT FRONT OF COVER
MORE THAN ¼ INCH. EXCESSIVE

FORCE APPLIED TO COVER MAY
BREAK REAR RETAINING CLIPS.

- a. Gently spread forward locking feet and lift front of cover.
- b. With the front of the cover raised, slide the cover to the rear to disengage it from the plug-in card.

To test a plug-in unit in the operating position, a circuit board extender card (M.I.I. Part No. 350-513-00 or equivalent) is required. The extender card brings the unit forward so components on circuit board are accessible for troubleshooting.

5.2.4 Disassembly of Plug-In Units in Card Racks

Except for SMR, access to units in racks is effected by removing dust cover over plug-in units. Surface Mounted Racks (SMR) do not have a cover over plug-in units since the whole rack may be enclosed into a NEMA box.

5.3 TROUBLESHOOTING

The schematic diagrams include flagged numbers (or letters) at various points in the circuit. Table 5-1 gives the voltages and waveforms at these points for specified input-signal conditions. The assembly drawing shows the physical locations of the parts on the circuit board. Bear in mind that the circuit board is protected with a moisture-resistant coating. Therefore, it may be necessary to use a needle-point probe and exert a fair amount of pressure to break through the coating when it is desired to observe the signal or voltage at a specific point. When connecting a probe to a component on the circuit board, exercise care to make sure the probe does not short-circuit to an adjacent component.

In general, troubleshooting is carried out by tracing the signal with an oscilloscope and referring to the schematic diagrams to determine what component might be causing an observed abnormal indication. If the original symptom was a complete failure of the unit to operate, the most logical components to suspect are those associated with the power supply in the unit (including any voltage regulators). If the unit was producing an incorrect (but not zero) output, check the outputs from the voltage regulator and, if these are normal, apply a standard input signal and trace the resulting signal through the unit.

SECTION 5

MAINTENANCE & TROUBLESHOOTING

5.3.1 Plug-In Board Connector Cleaning

Occasionally, modules which have been in service for a long period of time may develop resistive coatings on the gold-plated contacts of the plug-in boards. This coating, if allowed to build up, can cause malfunctions by decreasing the noise margin of a circuit.

There are two types of foreign material coatings which can develop on the gold-plated contacts of a plug-in module. The first type is INORGANIC. This type of contamination results when copper "bleeds" through the gold plating and oxidizes. The second form of contamination involves ORGANIC substances, which usually are a result of careless handling, and are mainly made up of fingerprints, salts, and oils deposited when the plug-in boards are handled by the gold-plated contacts. Contamination by organic substances can be greatly reduced by careful handling of the modules.

Although rack connectors are usually of the self-cleaning type, it may become necessary to clean the module fingers to ensure reliable connection. When module contacts are in need of cleaning, the following procedures are recommended:

Removal of Inorganic Contaminants

- a. Immerse contacts of plug-in board in an ultrasonic bath of deionized water and a detergent, such as Liguinyx, for at least 30 seconds.
- b. Repeat step (a) with pure deionized water only.

CAUTION

REMOVE WATER IMMEDIATELY FROM CONTACTS. IF THIS IS NOT DONE QUICKLY, DAMAGE TO CONTACTS MAY RESULT.

- c. Remove water by immersing contacts in an ethand or methanol bath to same depth used during the ultrasonic cleaning of step (a). Never wipe or use an abrasive cleaner on the contacts. If wiping is necessary, use K-Dry towels or equivalent.

Removal of Organic Contaminants

- a. After inorganic contaminants and water have been removed, organic materials may be removed by immersion of contacts in trichloroethane for at least 30 seconds.

CAUTION

NEVER USE AN ERASER ON THE CONTACTS. THE USE OF ABRASIVE CLEANERS OR ERASERS ON PLUG-IN BOARD CONTACTS IS CONSIDERED A PHYSICAL ABUSE TO THE PLUG-IN UNIT AND MAY VOID THE UNIT WARRANTY.

- b. Let contacts air dry or wipe with a very fine, nonabrasive material such as K-Dry towels or equivalent.

5.3.2 Component Replacement General Information

Replace all defective components with identical parts. Refer to Section 6 for a list of recommended replacement parts. The last row of numbers in the parts list is the number of spares recommended to be kept on hand for that part, per unit, for up to ten units of the same type. For more than ten units, a spares complement of 10% on the indicated parts should be used.

5.3.3 Component Replacement Techniques

Most parts used in the unit are quite small and are located in a confined area. Therefore, small hand tools are a necessity when servicing the unit. The following is a summary of the general techniques and precautions that should be observed to prevent damage to components in the unit:

CAUTION

CMOS INTEGRATED CIRCUITS ARE VERY SUSCEPTIBLE TO STATIC ELECTRICITY. WHEN REPLACING THESE COMPONENTS, DO NOT HANDLE LEADS BEFORE SOLDERING INTO BOARD. ENSURE THAT SOLDERING IRON IS GROUNDED. SOLDER INTEGRATED CIRCUITS LEAD V (POWER INPUT) BEFORE SOLDERING G (GROUND CONNECTION). FAILURE TO TAKE THESE PRECAUTIONS WILL DAMAGE COMPONENTS.

- a. Use a transformer-operated low-voltage soldering iron with a grounded tip and rated at not more than 50 watts. A temperature-controlled tip is desirable.
- b. Use extreme care when unsoldering the leads to any component. Do not keep the soldering iron on a point for more than a few seconds at a time. Use a suction-type solder-removing tool (solder sucker) as an aid in unsoldering transistors and integrated circuits. The protective coating on the unit may be removed with trichlorethane or equivalent. Be sure adequate ventilation is provided when using this or any other chemical.
- c. Do not excessively bend or twist the leads of small components; they break easily.
- d. Before removing a component, observe the lead dress. Be sure that the lead dress of the replacement is the same as that of the original.
- e. Remove all flux from soldered joints with trichlorethane or equivalent.
- f. Test and, if necessary, recalibrate the unit by the procedure given in Section 2. When the performance of the unit is known to be satisfactory, apply clear acrylic to reseal the unit where required.
- g. When reassembling unit, be sure to use the same screws (or screws of the same size) as the ones removed.

NOTE

Unused connections on integrated circuits are left unsoldered to aid in removal. Refer to the assembly drawing for more complete information.

TABLE 5-1. WAVEFORMS AND VOLTAGES (DC POWERED UNITS ONLY)

TEST POINTS	WAVEFORM AND AMPLITUDE
1	0.2 TO 1.0V ACCORDING TO SPAN SELECTION (0% TO 100%)
2	VOLTAGE OUTPUT: 1.7 TO 5.7V DC (0% TO 100%) CURRENT OUTPUT: 1.6 TO 2.4V DC (0% TO 100%)
3	SIGNIFICANT FOR CURRENT OUTPUT ONLY 0.2 TO 1.0V DC (0% TO 100%)
4	
5	

NOTE 1. WAVEFORM AMPLITUDE 24V DC = 48V PEAK TO PEAK } REFERENCED TO DCC
 45V DC = 90V PEAK TO PEAK }

2. TEST POINT VOLTAGES REFERENCED TO —IN UNLESS OTHERWISE SPECIFIED.

6.1 GENERAL

This section consists of a computer print-out table that provides parts identification information for the unit. Wiring lists have been provided in this section as an aid to the maintenance personnel.

Parts information is grouped according to the number of assemblies. If the unit contains two PC boards, the table will be divided into two major sections: one section will contain information related to PC1 and the other section will list PC2 components information. Each major section in the table contains a complete parts list headed LIST OF MATERIALS specifying which PC board it is describing. This list is usually found at the end of the section. The list of materials consists of the following headings:

ITEM: A reference numeral used for data processing and not used by maintenance personnel.

NAME: Gives the nomenclature of the part.

DESCRIPTION: Identifies the component by manufacturer's part number, usually followed by component's parameters or value.

REF: Lists the reference designation for the components described in Section 4 and illustrated in the schematics and assembly drawings.

PART NUMBER: This column specifies the Moore Industries assigned part number. This is the part identification required when ordering parts from Moore Industries.

SPARE: The numeral in this column specifies the recommended number of component spares per unit type that should be kept on hand by maintenance personnel.

6.2 GLOSSARY OF ABBREVIATIONS

C	Capacitor	R	Resistor
CR	Diode — Zener included	T	Transformer
HW	Special hardware	IC	Integrated circuit
J	Connecting buss wire	Q	Transistor
L	Inductor	LED	Light emitting diode
LB	Label	TB	Terminal block
PC	Printed circuit board	VS	Voltage regulating varistor
		VR	Voltage Regulator

DO NOT SCALE DRAWING	
TOLERANCES UNLESS NOTED	1/4" 1/8"
X ±.03	1/4" 1/8"
XX ±.010	1/4" 1/8"
XXX ±.010	1/4" 1/8"
ANGLES ±30'	

PLUG-IN
ECONOMY
SCT

DRAWING NUMBER	146-453-00	REVISED	E
CATEGORY	SCHEMATIC		
REVISED BY	ECO 2696	DATE	7/1/74
		BY	TUV
		CHKD	JL

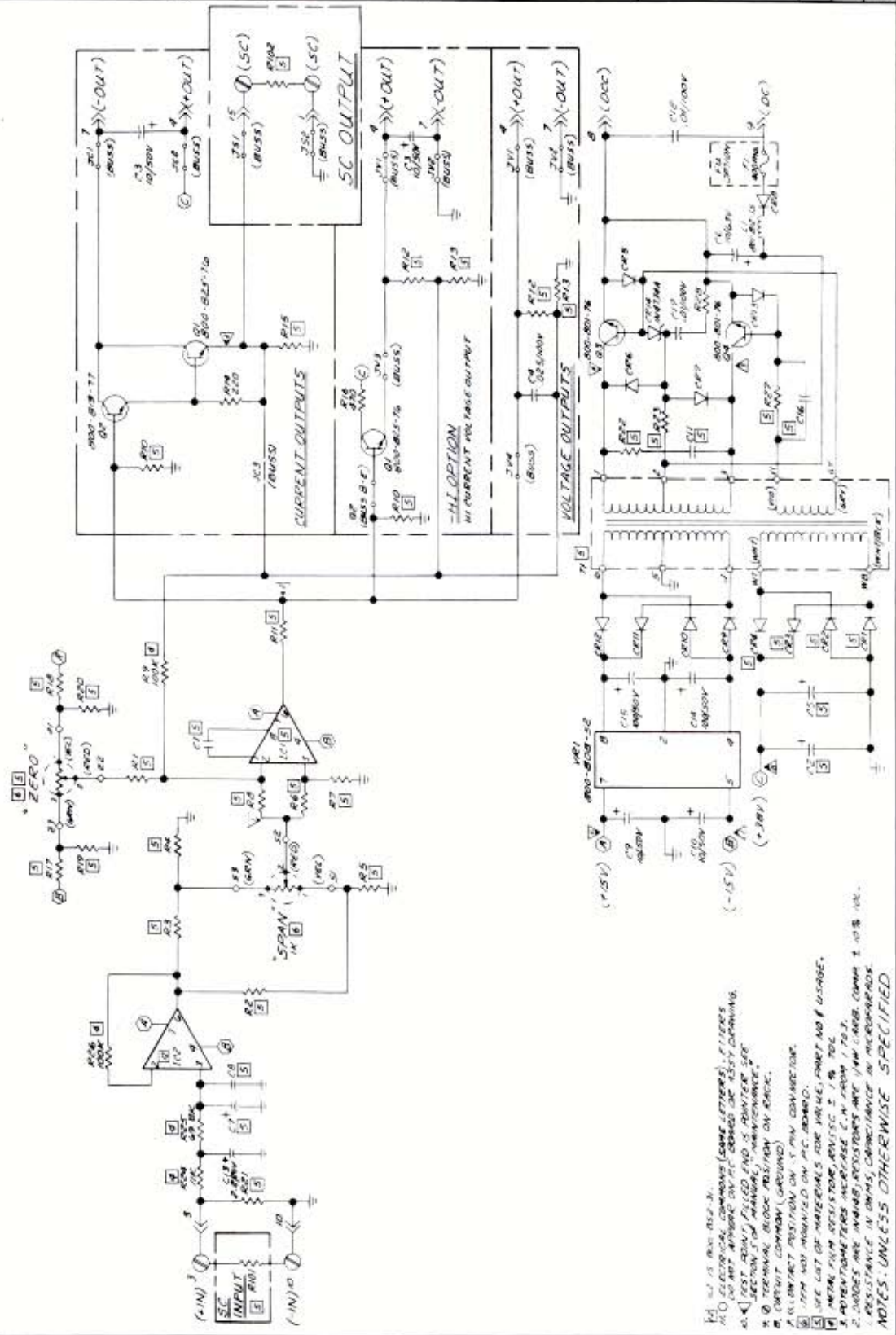

- NOTES: UNLESS OTHERWISE SPECIFIED.
1. ALL DIMENSIONS ARE IN MILLIMETERS (LESS LETTERS) UNLESS OTHERWISE NOTED.
 2. ALL DIMENSIONS ARE IN MILLIMETERS (LESS LETTERS) UNLESS OTHERWISE NOTED.
 3. ALL DIMENSIONS ARE IN MILLIMETERS (LESS LETTERS) UNLESS OTHERWISE NOTED.
 4. ALL DIMENSIONS ARE IN MILLIMETERS (LESS LETTERS) UNLESS OTHERWISE NOTED.
 5. ALL DIMENSIONS ARE IN MILLIMETERS (LESS LETTERS) UNLESS OTHERWISE NOTED.
 6. ALL DIMENSIONS ARE IN MILLIMETERS (LESS LETTERS) UNLESS OTHERWISE NOTED.
 7. ALL DIMENSIONS ARE IN MILLIMETERS (LESS LETTERS) UNLESS OTHERWISE NOTED.
 8. ALL DIMENSIONS ARE IN MILLIMETERS (LESS LETTERS) UNLESS OTHERWISE NOTED.
 9. ALL DIMENSIONS ARE IN MILLIMETERS (LESS LETTERS) UNLESS OTHERWISE NOTED.
 10. ALL DIMENSIONS ARE IN MILLIMETERS (LESS LETTERS) UNLESS OTHERWISE NOTED.

TOLERANCES	UNLESS OTHERWISE SPECIFIED
X	± .01
XX	± .03
XXX	± .010
ANGLES	± 30°

DATE	12-57	1/76
REV	1	1/16
REV	2	1/17
REV	2-1	

METAL SIDE DOWN
USE THERMO COMPOUND
BETWEEN Q1 & P.C. BOARD.

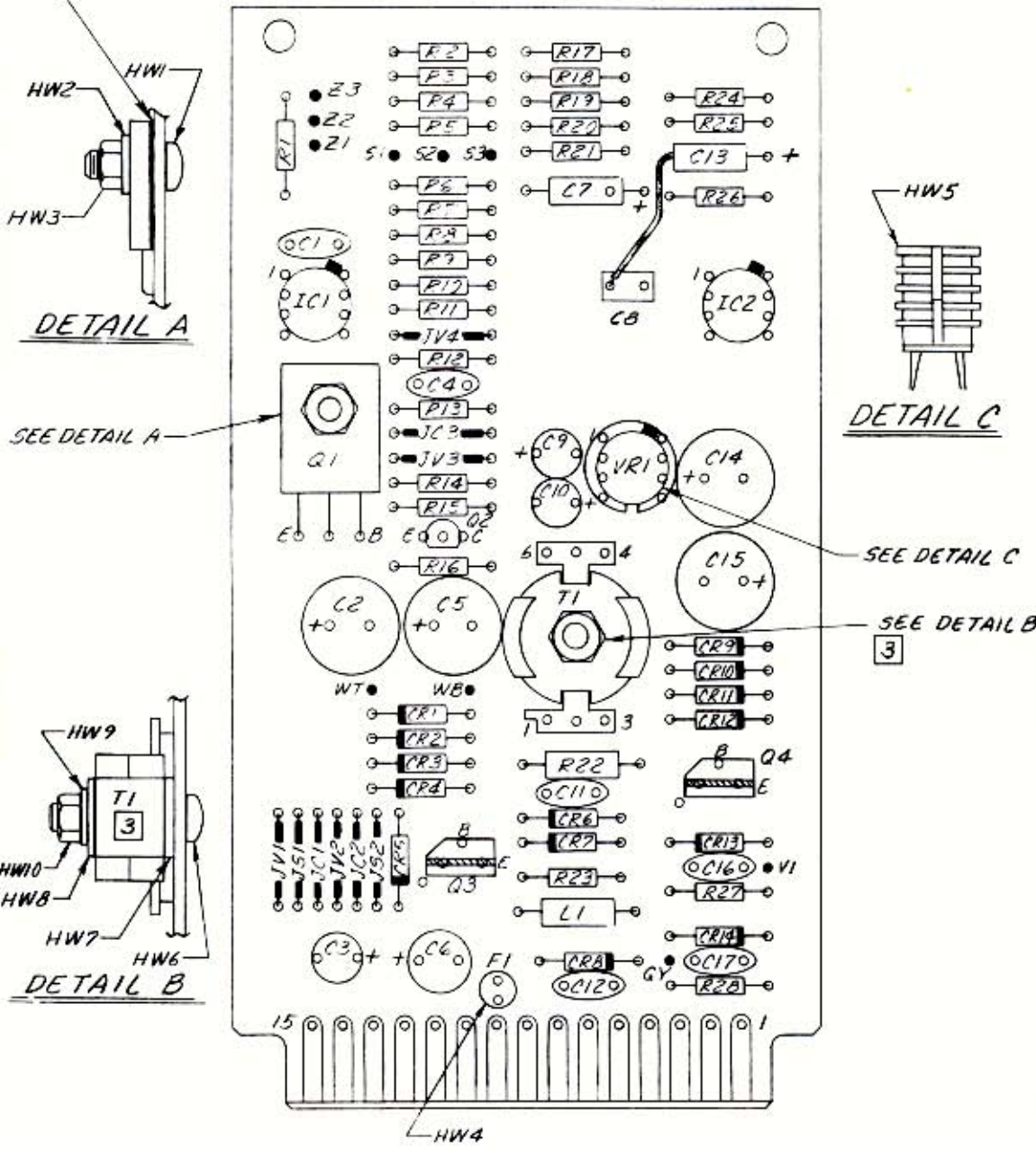

3. DO NOT OVER TIGHTEN SCREW, EXCESSIVE PRESSURE MAY BREAK POT CORE.
2. ALL LEADS MUST BE SOLDERED TO PADS.
1. JUMPERS ARE 22AWG, TEFLON SLEEVED AS REQ'D.
NOTES: UNLESS OTHERWISE SPECIFIED.

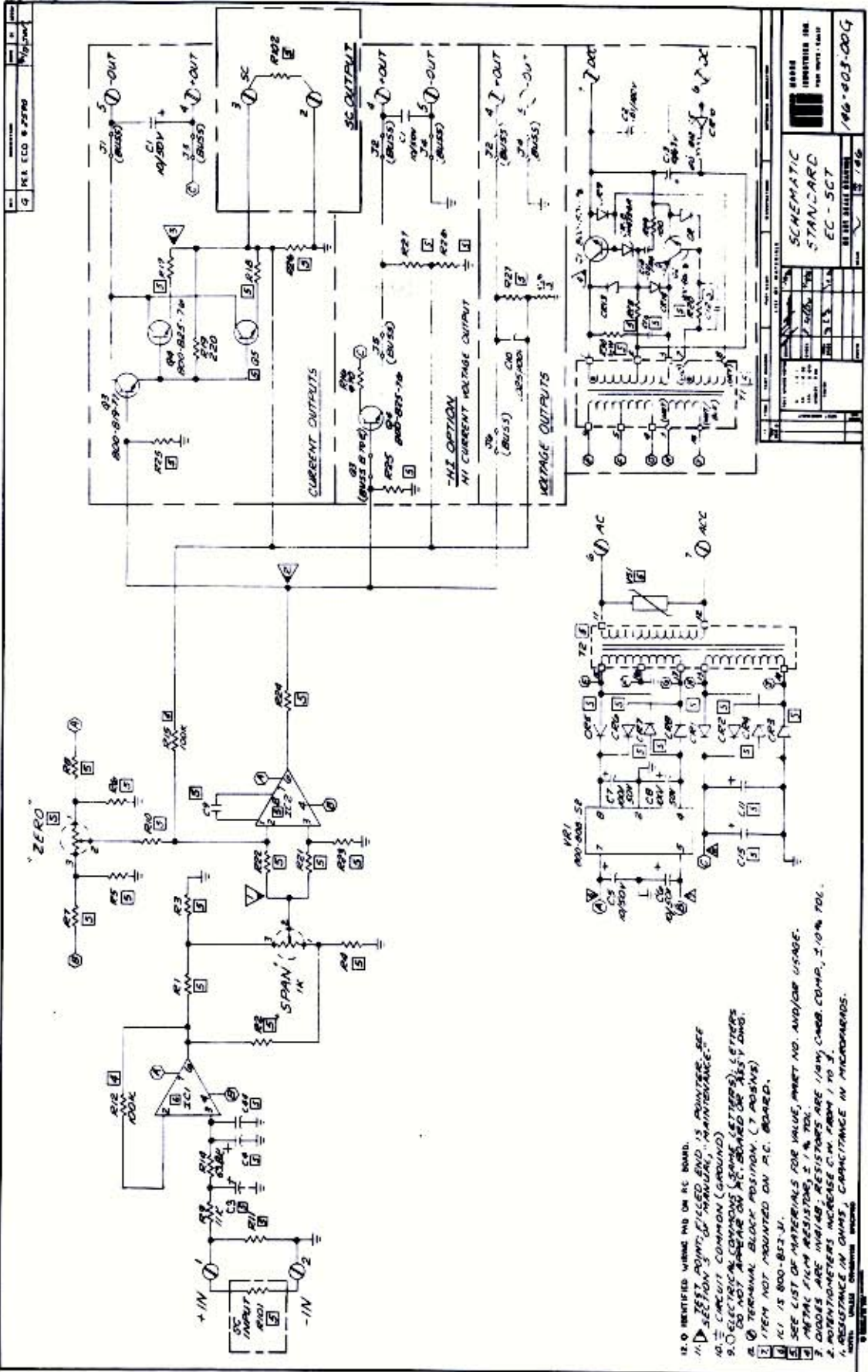

G MIL ECO 8 2290

SCHEMATIC STANDARD EC - SCT

1. 0 IDENTIFIED WIRING NO ON PC BOARD.
2. 1/2 WATT POINT TO POINT. 1/2 WATT. SEE SECTION 3.0.
3. METAL FILM RESISTORS, 1% TOL.
4. DIODES ARE INVAR, RESISTORS ARE 1/8W, COMB. COAR, 1/10% TOL.
5. POSITIONERS INCREASE C.W. FROM 1 TO 3.
6. CAPACITANCE IN OHMS, CAPACITANCE IN MICROFARADS.
7. ITEM NOT MOUNTED ON P.C. BOARD.
8. IC1 IS 800-823-V.
9. SEE LIST OF MATERIALS FOR VALUE, PART NO. AND/OR USAGE.
10. METAL FILM RESISTORS, 1% TOL.
11. DIODES ARE INVAR, RESISTORS ARE 1/8W, COMB. COAR, 1/10% TOL.
12. POSITIONERS INCREASE C.W. FROM 1 TO 3.
13. CAPACITANCE IN OHMS, CAPACITANCE IN MICROFARADS.
14. ITEM NOT MOUNTED ON P.C. BOARD.
15. IC1 IS 800-823-V.
16. SEE LIST OF MATERIALS FOR VALUE, PART NO. AND/OR USAGE.
17. METAL FILM RESISTORS, 1% TOL.
18. DIODES ARE INVAR, RESISTORS ARE 1/8W, COMB. COAR, 1/10% TOL.
19. POSITIONERS INCREASE C.W. FROM 1 TO 3.
20. CAPACITANCE IN OHMS, CAPACITANCE IN MICROFARADS.
21. ITEM NOT MOUNTED ON P.C. BOARD.
22. IC1 IS 800-823-V.
23. SEE LIST OF MATERIALS FOR VALUE, PART NO. AND/OR USAGE.
24. METAL FILM RESISTORS, 1% TOL.
25. DIODES ARE INVAR, RESISTORS ARE 1/8W, COMB. COAR, 1/10% TOL.
26. POSITIONERS INCREASE C.W. FROM 1 TO 3.
27. CAPACITANCE IN OHMS, CAPACITANCE IN MICROFARADS.
28. ITEM NOT MOUNTED ON P.C. BOARD.
29. IC1 IS 800-823-V.
30. SEE LIST OF MATERIALS FOR VALUE, PART NO. AND/OR USAGE.
31. METAL FILM RESISTORS, 1% TOL.
32. DIODES ARE INVAR, RESISTORS ARE 1/8W, COMB. COAR, 1/10% TOL.
33. POSITIONERS INCREASE C.W. FROM 1 TO 3.
34. CAPACITANCE IN OHMS, CAPACITANCE IN MICROFARADS.
35. ITEM NOT MOUNTED ON P.C. BOARD.
36. IC1 IS 800-823-V.
37. SEE LIST OF MATERIALS FOR VALUE, PART NO. AND/OR USAGE.
38. METAL FILM RESISTORS, 1% TOL.
39. DIODES ARE INVAR, RESISTORS ARE 1/8W, COMB. COAR, 1/10% TOL.
40. POSITIONERS INCREASE C.W. FROM 1 TO 3.
41. CAPACITANCE IN OHMS, CAPACITANCE IN MICROFARADS.
42. ITEM NOT MOUNTED ON P.C. BOARD.
43. IC1 IS 800-823-V.
44. SEE LIST OF MATERIALS FOR VALUE, PART NO. AND/OR USAGE.
45. METAL FILM RESISTORS, 1% TOL.
46. DIODES ARE INVAR, RESISTORS ARE 1/8W, COMB. COAR, 1/10% TOL.
47. POSITIONERS INCREASE C.W. FROM 1 TO 3.
48. CAPACITANCE IN OHMS, CAPACITANCE IN MICROFARADS.
49. ITEM NOT MOUNTED ON P.C. BOARD.
50. IC1 IS 800-823-V.
51. SEE LIST OF MATERIALS FOR VALUE, PART NO. AND/OR USAGE.
52. METAL FILM RESISTORS, 1% TOL.
53. DIODES ARE INVAR, RESISTORS ARE 1/8W, COMB. COAR, 1/10% TOL.
54. POSITIONERS INCREASE C.W. FROM 1 TO 3.
55. CAPACITANCE IN OHMS, CAPACITANCE IN MICROFARADS.
56. ITEM NOT MOUNTED ON P.C. BOARD.
57. IC1 IS 800-823-V.
58. SEE LIST OF MATERIALS FOR VALUE, PART NO. AND/OR USAGE.
59. METAL FILM RESISTORS, 1% TOL.
60. DIODES ARE INVAR, RESISTORS ARE 1/8W, COMB. COAR, 1/10% TOL.
61. POSITIONERS INCREASE C.W. FROM 1 TO 3.
62. CAPACITANCE IN OHMS, CAPACITANCE IN MICROFARADS.
63. ITEM NOT MOUNTED ON P.C. BOARD.
64. IC1 IS 800-823-V.
65. SEE LIST OF MATERIALS FOR VALUE, PART NO. AND/OR USAGE.
66. METAL FILM RESISTORS, 1% TOL.
67. DIODES ARE INVAR, RESISTORS ARE 1/8W, COMB. COAR, 1/10% TOL.
68. POSITIONERS INCREASE C.W. FROM 1 TO 3.
69. CAPACITANCE IN OHMS, CAPACITANCE IN MICROFARADS.
70. ITEM NOT MOUNTED ON P.C. BOARD.
71. IC1 IS 800-823-V.
72. SEE LIST OF MATERIALS FOR VALUE, PART NO. AND/OR USAGE.
73. METAL FILM RESISTORS, 1% TOL.
74. DIODES ARE INVAR, RESISTORS ARE 1/8W, COMB. COAR, 1/10% TOL.
75. POSITIONERS INCREASE C.W. FROM 1 TO 3.
76. CAPACITANCE IN OHMS, CAPACITANCE IN MICROFARADS.
77. ITEM NOT MOUNTED ON P.C. BOARD.
78. IC1 IS 800-823-V.
79. SEE LIST OF MATERIALS FOR VALUE, PART NO. AND/OR USAGE.
80. METAL FILM RESISTORS, 1% TOL.
81. DIODES ARE INVAR, RESISTORS ARE 1/8W, COMB. COAR, 1/10% TOL.
82. POSITIONERS INCREASE C.W. FROM 1 TO 3.
83. CAPACITANCE IN OHMS, CAPACITANCE IN MICROFARADS.
84. ITEM NOT MOUNTED ON P.C. BOARD.
85. IC1 IS 800-823-V.
86. SEE LIST OF MATERIALS FOR VALUE, PART NO. AND/OR USAGE.
87. METAL FILM RESISTORS, 1% TOL.
88. DIODES ARE INVAR, RESISTORS ARE 1/8W, COMB. COAR, 1/10% TOL.
89. POSITIONERS INCREASE C.W. FROM 1 TO 3.
90. CAPACITANCE IN OHMS, CAPACITANCE IN MICROFARADS.
91. ITEM NOT MOUNTED ON P.C. BOARD.
92. IC1 IS 800-823-V.
93. SEE LIST OF MATERIALS FOR VALUE, PART NO. AND/OR USAGE.
94. METAL FILM RESISTORS, 1% TOL.
95. DIODES ARE INVAR, RESISTORS ARE 1/8W, COMB. COAR, 1/10% TOL.
96. POSITIONERS INCREASE C.W. FROM 1 TO 3.
97. CAPACITANCE IN OHMS, CAPACITANCE IN MICROFARADS.
98. ITEM NOT MOUNTED ON P.C. BOARD.
99. IC1 IS 800-823-V.
100. SEE LIST OF MATERIALS FOR VALUE, PART NO. AND/OR USAGE.

MOORE INDUSTRIES
16650 Schoenborn Street
Sepulveda, California 91343

DO NOT SCALE DRAWING
TOLERANCES
UNLESS NOTED
X ±.1
XX ±.03
XXX ±.010
ANGLES ±.30°
SCALE 2/1

**STANDARD
EC-5CT**

146-503-00 G
P.C. ASSEMBLY
ECO 2590

PAGE 1 OF 2

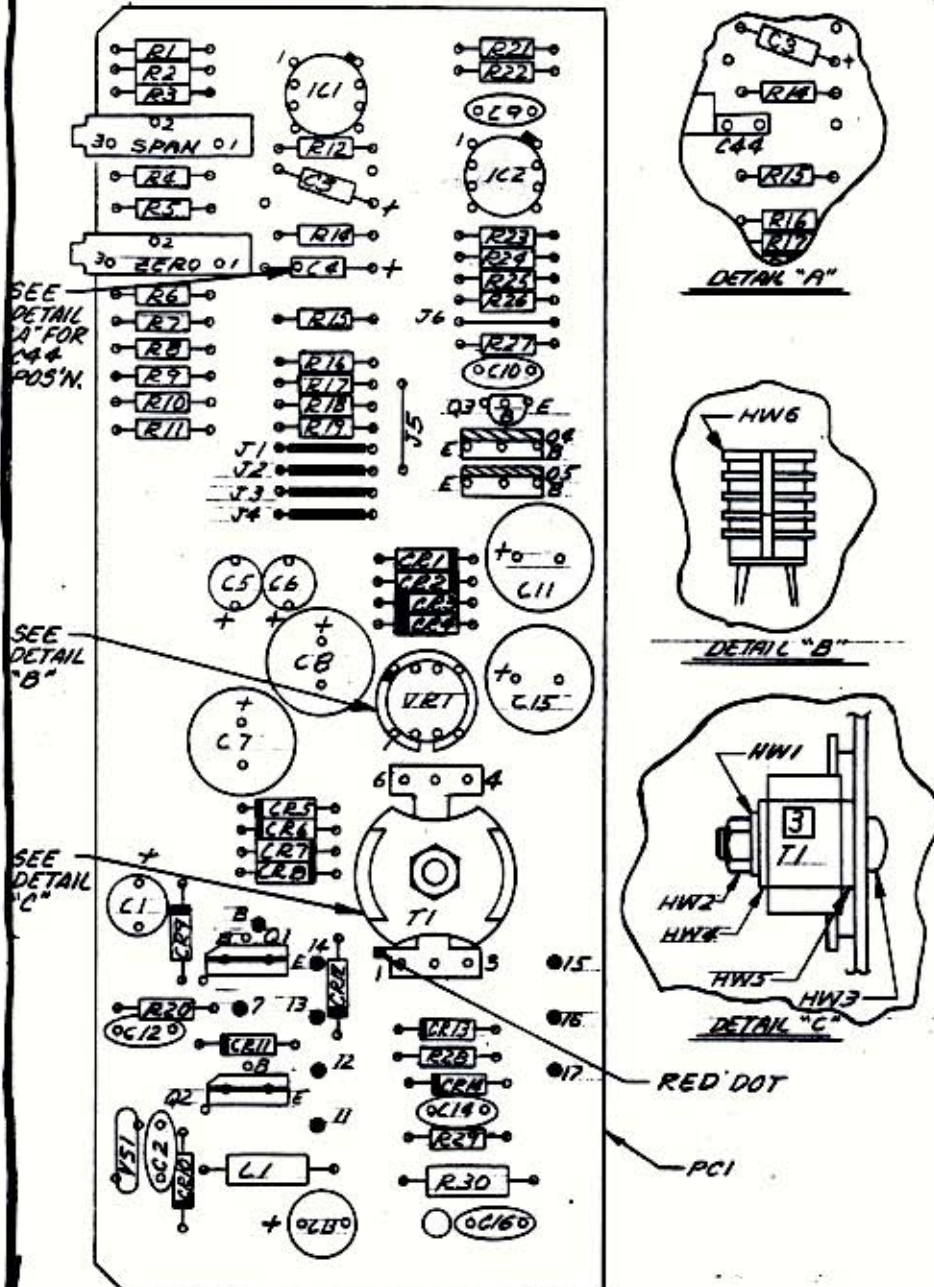

6. SEE PAGE 2 FOR ADDITIONAL COMPONENT LOCATIONS.
5. ALL LEADS MUST BE SOLDERED TO PADS.
4. FOR MOUNTING OF T2, INSERT TABS (2) IN BOARD & BEND TOWARD EACH OTHER.
3. DO NOT OVER-TIGHTEN SCREW WHEN MOUNTING T1. EXCESSIVE PRESSURE MAY BREAK POT CORE.
2. METELIZED SIDE OF Q4 & Q5.
1. ALL JUMPERS 22 AWG BUSS, TEFLON SLEEVED AS REQUIRED.
NOTES (UNLESS OTHERWISE SPECIFIED)

DRAWING NUMBER
146-503-00

CATEGORY
P.C. ASSEMBLY

DATE
 1/14/76

BY
 [Signature]

APPROVED
 [Signature]

STANDARD

EC-SCT

DO NOT SCALE DRAWING

DRAWN S. GOSSETT	3/25/76
CHECKED R. KELLY	7/14/76
ENGINEER DRS	7/14/76

TOLERANCES UNLESS NOTED
 .X ±.1
 .XX ±.03
 .XXX ±.010
 ANGLES ±30'

SCALE

MOORE INDUSTRIES
 16650 Schoenborn Street
 Sepulveda, California 91343

PAGE 2 OF 2

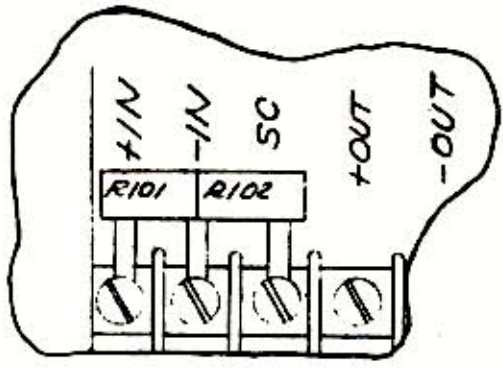
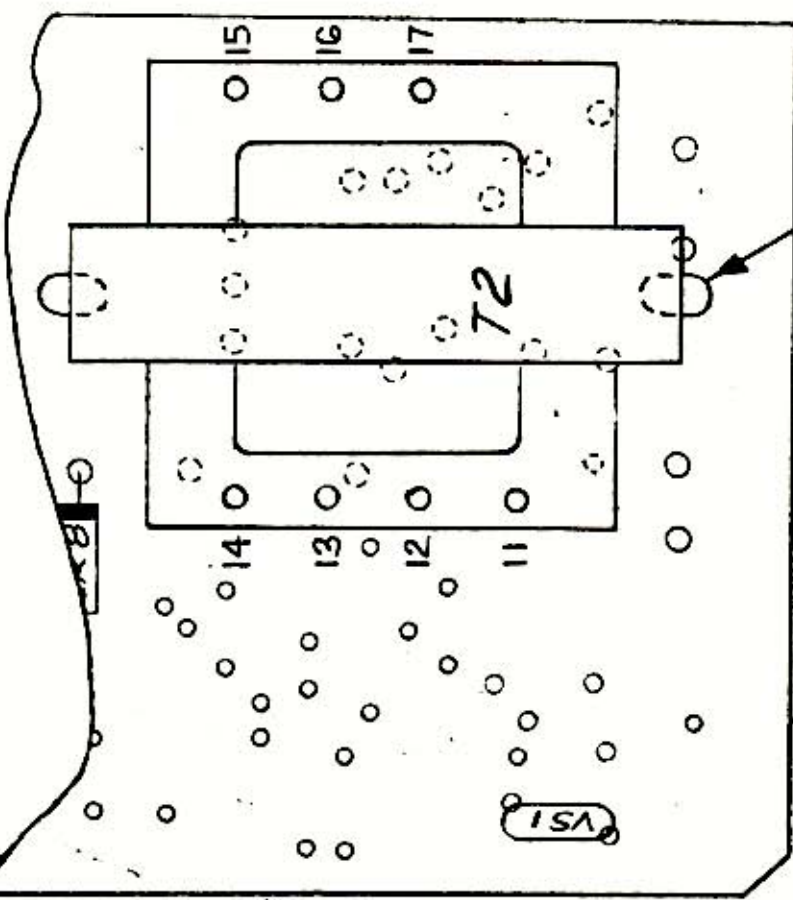

MOUNTING OF R101
 & R102.

RETURN PROCEDURES

To return equipment to Moore Industries for repair, follow these four steps:

1. Call Moore Industries and request a Returned Material Authorization (RMA) number.

Warranty Repair –

If you are unsure if your unit is still under warranty, we can use the unit's serial number to verify the warranty status for you over the phone. Be sure to include the RMA number on all documentation.

Non-Warranty Repair –

If your unit is out of warranty, be prepared to give us a Purchase Order number when you call. In most cases, we will be able to quote you the repair costs at that time. The repair price you are quoted will be a "Not To Exceed" price, which means that the actual repair costs may be less than the quote. Be sure to include the RMA number on all documentation.

2. Provide us with the following documentation:
 - a) A note listing the symptoms that indicate the unit needs repair
 - b) Complete shipping information for return of the equipment after repair
 - c) The name and phone number of the person to contact if questions arise at the factory
3. Use sufficient packing material and carefully pack the equipment in a sturdy shipping container.
4. Ship the equipment to the Moore Industries location nearest you.

The returned equipment will be inspected and tested at the factory. A Moore Industries representative will contact the person designated on your documentation if more information is needed. The repaired equipment, or its replacement, will be returned to you in accordance with the shipping instructions furnished in your documentation.

WARRANTY DISCLAIMER

THE COMPANY MAKES NO EXPRESS, IMPLIED OR STATUTORY WARRANTIES (INCLUDING ANY WARRANTY OF MERCHANTABILITY OR OF FITNESS FOR A PARTICULAR PURPOSE) WITH RESPECT TO ANY GOODS OR SERVICES SOLD BY THE COMPANY. THE COMPANY DISCLAIMS ALL WARRANTIES ARISING FROM ANY COURSE OF DEALING OR TRADE USAGE, AND ANY BUYER OF GOODS OR SERVICES FROM THE COMPANY ACKNOWLEDGES THAT THERE ARE NO WARRANTIES IMPLIED BY CUSTOM OR USAGE IN THE TRADE OF THE BUYER AND OF THE COMPANY, AND THAT ANY PRIOR DEALINGS OF THE BUYER WITH THE COMPANY DO NOT IMPLY THAT THE COMPANY WARRANTS THE GOODS OR SERVICES IN ANY WAY.

ANY BUYER OF GOODS OR SERVICES FROM THE COMPANY AGREES WITH THE COMPANY THAT THE SOLE AND EXCLUSIVE REMEDIES FOR BREACH OF ANY WARRANTY CONCERNING THE GOODS OR SERVICES SHALL BE FOR THE COMPANY, AT ITS OPTION, TO REPAIR OR REPLACE THE GOODS OR SERVICES OR REFUND THE PURCHASE PRICE. THE COMPANY SHALL IN NO EVENT BE LIABLE FOR ANY CONSEQUENTIAL OR INCIDENTAL DAMAGES EVEN IF THE COMPANY FAILS IN ANY ATTEMPT TO REMEDY DEFECTS IN THE GOODS OR SERVICES, BUT IN SUCH CASE THE BUYER SHALL BE ENTITLED TO NO MORE THAN A REFUND OF ALL MONIES PAID TO THE COMPANY BY THE BUYER FOR PURCHASE OF THE GOODS OR SERVICES.

ANY CAUSE OF ACTION FOR BREACH OF ANY WARRANTY BY THE COMPANY SHALL BE BARRED UNLESS THE COMPANY RECEIVES FROM THE BUYER A WRITTEN NOTICE OF THE ALLEGED DEFECT OR BREACH WITHIN TEN DAYS FROM THE EARLIEST DATE ON WHICH THE BUYER COULD REASONABLY HAVE DISCOVERED THE ALLEGED DEFECT OR BREACH, AND NO ACTION FOR THE BREACH OF ANY WARRANTY SHALL BE COMMENCED BY THE BUYER ANY LATER THAN TWELVE MONTHS FROM THE EARLIEST DATE ON WHICH THE BUYER COULD REASONABLY HAVE DISCOVERED THE ALLEGED DEFECT OR BREACH.

RETURN POLICY

For a period of thirty-six (36) months from the date of shipment, and under normal conditions of use and service, Moore Industries ("The Company") will at its option replace, repair or refund the purchase price for any of its manufactured products found, upon return to the Company (transportation charges prepaid and otherwise in accordance with the return procedures established by The Company), to be defective in material or workmanship. This policy extends to the original Buyer only and not to Buyer's customers or the users of Buyer's products, unless Buyer is an engineering contractor in which case the policy shall extend to Buyer's immediate customer only. This policy shall not apply if the product has been subject to alteration, misuse, accident, neglect or improper application, installation, or operation. THE COMPANY SHALL IN NO EVENT BE LIABLE FOR ANY INCIDENTAL OR CONSEQUENTIAL DAMAGES.



WORLDWIDE • www.miinet.com

United States • info@miinet.com Tel: (818) 894-7111 • FAX: (818) 891-2816	Belgium • info@mooreind.be Tel: 03/448.10.18 • FAX: 03/440.17.97	China • sales@mooreind.sh.cn Tel: 86-21-62491499 • FAX: 86-21-62490635
Australia • sales@mooreind.com.au Tel: (02) 8536-7200 • FAX: (02) 9525-7296	The Netherlands • sales@mooreind.nl Tel: (0)344-617971 • FAX: (0)344-615920	United Kingdom • sales@mooreind.com Tel: 01293 514488 • FAX: 01293 536852